

Product Specifications

50ESN43GD3

The NeoTek™ fastening system is the next generation of smart tool solutions. The lightweight, ergonomic design along with fully programmable features such as the high-output LED light rings, audible alerts, and handle vibration all create a better user experience that leads to decreased operator fatigue and increased productivity.

FEATURES

- 1 million cycles maintenance-free*
- Repeatability & accuracy with 2.0 Cm/Cmk at +/- 7%
- 21% lighter (tool/cable system) than existing tool family
- Digital communication for reliable performance
- Internal temperature monitoring
- Configurable LED light rings
- Data logging with on-board tool memory
- Preventive maintenance alerts

SPECIFICATIONS

TORQUE RANGE (Nm)

Min / Max: 9.0 / 43

TORQUE RANGE (ft·lb)

Min / Max: 6.6 / 31.7

SPEED

r/min: 1,375

WEIGHT & DIMENSIONS

Weight 1.65 kg / 3.64 lb
 Length 403 mm / 15.86 in
 Side to Center 18.9 mm / 0.74 in
 Output Drive 3/8" Sq. Drive

Country of Origin: Assembled in USA



INLINE CORDED NUTRUNNER
 9.0 - 43 Nm (6.6 – 31.7 ft·lbs)

INLINE - 50 SERIES

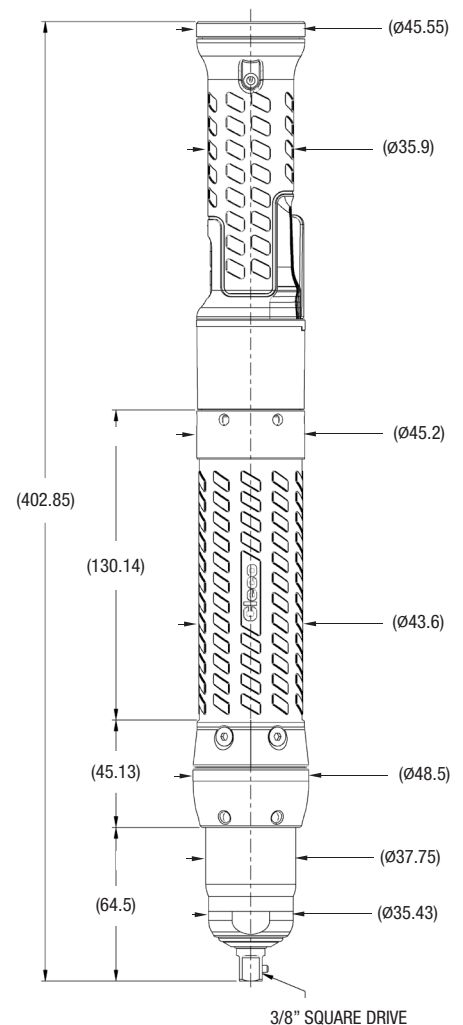

*based on recommended tool model torque range and clockwise rotation