

Cleco

P2562MA-INT
REV B | 2024-02

CellTek™

AC(...)00-R0-G0-LSI



Copyright © 2024 Apex Brands, Inc. All rights reserved.

Disclaimer

Apex Tool Group reserves the right to modify, supplement, or improve this document or the product without prior notice.

Trademark

Cleco is a registered trademark of Apex Brands, Inc.

Apex Tool Group

670 Industrial Drive
Lexington, SC 29072
USA

Manufacturer

Apex Tool Group GmbH
Industriestraße 1
73463 Westhausen
Germany

CTBAW(...)

1

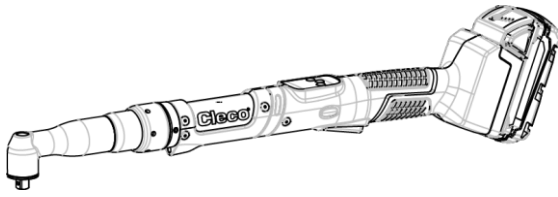

2

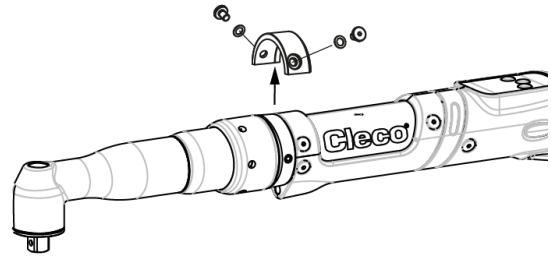

3

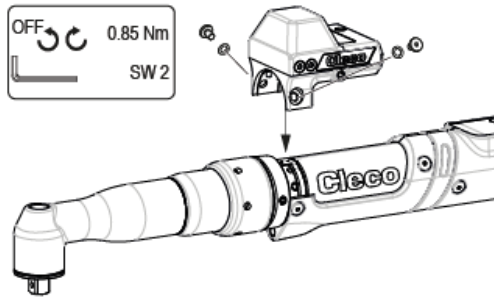

4

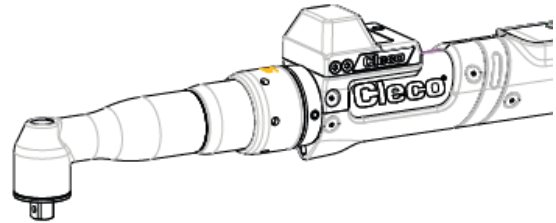

CTBPW(...)

1

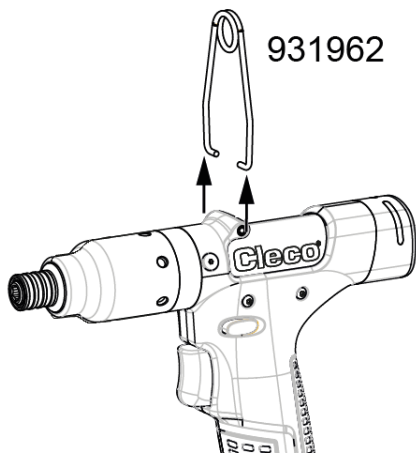

2

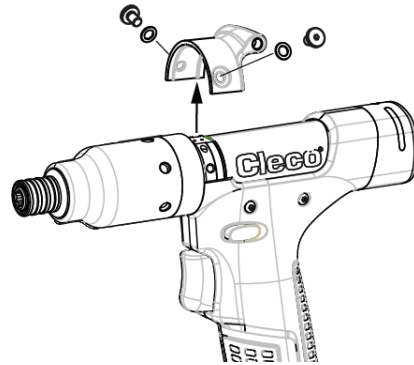

3

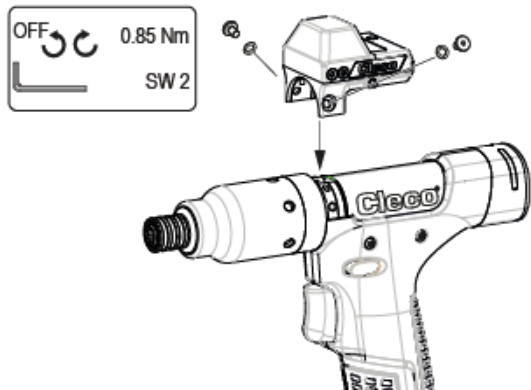

4

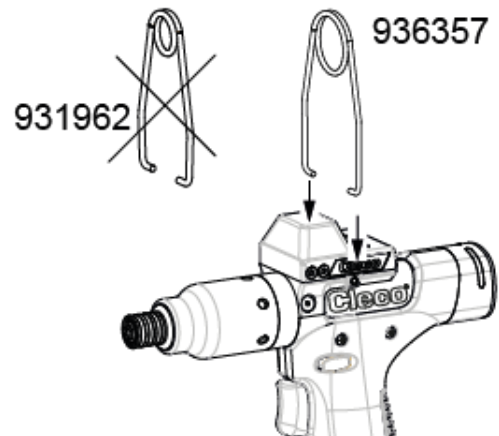

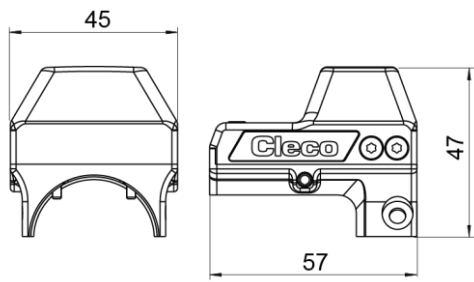
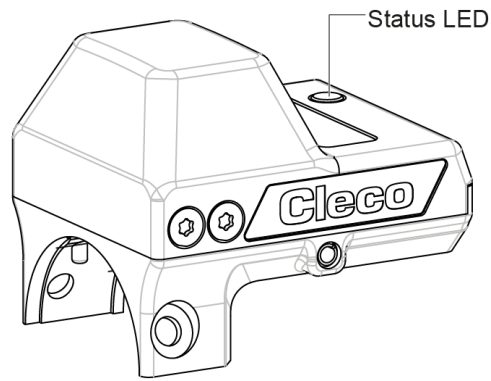

Nomenclature

| Präfix | A | C | P A | 00 SA | R0 R2 R3 | G0 G1 | L00 LD4 LSI LNA LKI |
|--------------|---|---|--------|----------|----------------|----------|---------------------------------|
| Accessory | | | | | | | |
| Tool Family | CellTek | | | | | | |
| Tool Type | P – Pistol A – Angle Head | | | | | | |
| Adapter Size | 00 – No specific SA – Stay Alive | | | | | | |
| Front Option | R0 – No Reader R2 – Reader 2D Matrix (Laser Aimer) R3 – Reader 2D Matrix (no Laser Aimer) | | | | | | |
| Gyro Option | G0 – No Gyro G1 – Gyro | | | | | | |
| Localisation | L00 – No TAG LD4 – Ubisense D4 LSI – SIMATIC RTLS LNA – NATEV LKI – KINEXON | | | | | | |

Content

EN

| | | |
|---|------------------------------|---|
| 1 | About this Document | 7 |
| 2 | Software Requirements | 7 |
| 3 | Product Description | 7 |
| 4 | Installation | 7 |
| 5 | Activating accessories | 7 |
| 6 | LED Display | 7 |
| 7 | Ambient conditions | 7 |
| 8 | Troubleshooting | 8 |

DE

| | | |
|---|-----------------------------|----|
| 1 | Zu diesem Dokument | 9 |
| 2 | Softwareanforderungen | 9 |
| 3 | Produktbeschreibung | 9 |
| 4 | Installation | 9 |
| 5 | Zubehör aktivieren | 9 |
| 6 | LED-Anzeige | 9 |
| 7 | Umgebungsbedingungen | 9 |
| 8 | Fehlersuche | 10 |

1 About this Document

This document is intended for specialists in installation and maintenance (administrators, maintenance staff, service personnel, owners/operators). It contains information on safe and proper installation. The original language of this document is German.

Other Documents

| Number | Document |
|---------|--|
| P2544PM | Programming Manual – S169263 CTBA & CTBP |

2 Software Requirements

- Bootloader: S169353-101 or later
- Controller: e.g., S168813-1.9 or later
- Measurement card: S169263-212 or later

3 Product Description



| Tool | Module Order no. |
|------------|------------------|
| Angle head | ACA00-R0-G0-LSI |
| Pistol | ACP00-R0-G0-LSI |

The TAG module allows CellTek tools to be located within a position system.

4 Installation

Angle head: see figure see CTBAW(...), page 3.

Pistol: see figure see CTBPW(...), page 3.





| | |
|---|--|
|  | <p>Caution</p> <p>Winding hazard Unintentional pressing of the start trigger can cause the drive to turn and cause serious finger injuries.</p> <ul style="list-style-type: none"> ▶ Disconnect the tool from the power supply when converting work. |
|  | <p>Note</p> <p>Malfunction Accessories can be initialized incorrectly at start-up if the tool was not completely switched off during installation.</p> <ul style="list-style-type: none"> ▶ Before installing, remove the battery and wait approx. 20 seconds for the tool to stop working. |

5 Activating accessories

The accessory is active as soon as it has been installed. No additional activation is necessary. For further settings, see the respective software documentation for the control and the documentation for the tool.

6 LED Display

Status LED

| Color | Explanation |
|---|--|
|  Continuous green light | Ready |
|  Flashing yellow light | Initialization. If more than 20 seconds, see Troubleshooting. |
|  Continuous red light | See Troubleshooting. |
|  Continuous white light | Software update is running. Do not interrupt the power supply. |

7 Ambient conditions

- EMC Limit Class A (electromagnetic immunity for industrial areas)
- Recommendation: ESD workstation on installation

| Features | Data |
|-------------------------------|--|
| Operation site | Indoors |
| Working temperature | 0 °C – 45 °C |
| Storage temperature | -25 °C – 70 °C |
| Type of cooling | Convection (self-cooling) |
| Relative humidity | 10 % – 90 %, no condensation |
| Working height | Up to 3 000 m (9,843 ft) above sea level |
| Degree of protection EN 60529 | IP40 |

8 Troubleshooting

| Problem | Possible cause | Measure |
|---|-------------------------------------|---|
| Module does not work | Tool not active | ▶ Press the start switch on the tool |
| | Module not properly installed | ▶ Check installation |
| | Module not activated by software | ▶ Reattach the battery ▶ Restart tool |
| | Wrong software on tool | ▶ Perform software update with correct software |
| | Tool defective | ▶ Replace tool |
| | Module defective | ▶ Replace module |
| Status LED: Flashlight yellow for longer than 20 seconds | Initialization of the module failed | ▶ Reinsert the battery ▶ Restart the tool |
| | Module not properly installed | ▶ Check assembly |
| | Software out of date | ▶ Update CellTek Firmware see <i>software.apextoolgroup.com</i> |
| | Module defective | ▶ Exchange module |
| | Tool defective | ▶ Exchange tool |
| Status LED: Continuous red light after switching on | Initialization of the module failed | ▶ Reattach the battery ▶ Restart tool |
| | Module defective | ▶ Replace module |
| Status LED: Off after successful initialization | Power supply no longer active | ▶ Press the start switch on the tool |

1 Zu diesem Dokument

Dieses Dokument richtet sich an Fachkräfte für Installation und Instandhaltung (Administratoren, Instandhalter, Service, Betreiber).

Es enthält Informationen zum sicheren und sachgerechten Einbau.

Die Originalsprache dieses Dokuments ist Deutsch.

Weiterführende Dokumente

| Nummer | Dokument |
|---------|--|
| P2544PM | Programmieranleitung – S169263 CTBA & CTBP |

2 Softwareanforderungen

- Bootloader: S169353-101 oder neuer
- Steuerung: z. B. S168813-1.9 oder neuer
- Messkarte: S169263-212 oder neuer

3 Produktbeschreibung

| Werkzeug | Modul Bestell-Nr. |
|------------|-------------------|
| Winkelkopf | ACA00-R0-G0-LSI |
| Pistole | ACP00-R0-G0-LSI |

Das TAG Modul ermöglicht das Orten von Werkzeugen innerhalb eines Ortungssystems.

4 Installation

Winkelkopf: siehe Abbildung *siehe CTBAW(...), Seite 3.*

Pistole: siehe Abbildung *siehe CTBPW(...), Seite 3.*

| | |
|---|---|
|  | Vorsicht |
| | <p>Aufwicklungsgefahr Unbeabsichtigtes Betätigen des Startschalters kann zum Drehen des Antriebs führen und schwere Fingererletzungen verursachen.</p> <p>► Das Werkzeug bei Umrüstarbeiten von der Stromversorgung trennen.</p> |





| | |
|---|---|
|  | Hinweis |
| | <p>Funktionsstörung Zubehör kann beim Start falsch initialisiert werden, wenn das Werkzeug bei der Installation nicht komplett ausgeschaltet war.</p> <p>► Vor der Installation den Akku entfernen und ca. 20 Sekunden warten, bis das Werkzeug außer Betrieb ist.</p> |

5 Zubehör aktivieren

Das Zubehör ist aktiv, sobald es montiert wurde. Es ist keine zusätzliche Aktivierung notwendig. Weitere Einstellungen siehe jeweilige Softwaredokumentation der Steuerung sowie Dokumentation des Werkzeugs.

6 LED-Anzeige

Status LED

| Farbe | Bedeutung |
|---|---|
|  Dauerlicht Grün | Bereit |
|  Blinklicht Gelb | Initialisierung. Wenn länger als 20 Sekunden, siehe Fehlersuche. |
|  Dauerlicht Rot | Siehe Fehlersuche. |
|  Dauerlicht Weiß | Software-Update läuft. Energieversorgung nicht unterbrechen. |

7 Umgebungsbedingungen

- EMV-Grenzwertklasse A (Störfestigkeit für Industriebereiche)
- Empfehlung: ESD Arbeitsplatz bei Installation

| Merkmale | Daten |
|---------------------------|-----------------------------|
| Einsatzort | In Innenräumen |
| Arbeitstemperatur | 0 °C – 45 °C |
| Lagertemperatur | -25 °C – 70 °C |
| Kühlungsart | Konvektion (Eigenkühlung) |
| Relative Luftfeuchtigkeit | 10 % – 90 %, keine Betauung |
| Arbeitshöhe | Bis 3 000 m über NN |
| Schutzart EN 60529 | IP40 |

8 Fehlersuche

| Problem | Mögliche Ursache | Maßnahme |
|---|---|---|
| Modul funktioniert nicht | Werkzeug nicht aktiv | ▶ Startschalter am Werkzeug betätigen |
| | Modul nicht richtig montiert | ▶ Montage prüfen |
| | Modul durch Software nicht aktiviert | ▶ Akku neu stecken ▶ Werkzeug neu starten |
| | Falsche Software auf Werkzeug | ▶ Software-Update mit richtiger Software durch führen |
| | Werkzeug defekt | ▶ Werkzeug tauschen |
| | Modul defekt | ▶ Modul tauschen |
| Status LED: Blinklicht Gelb länger als 20 Sekunden | Initialisierung des Moduls fehlgeschlagen | ▶ Akku neu stecken ▶ Werkzeug neu starten |
| | Modul nicht richtig montiert | ▶ Montage prüfen |
| | Software nicht aktuell | ▶ Update CellTek Firmware siehe software.apextoolgroup.com |
| | Modul defekt | ▶ Modul tauschen |
| | Werkzeug defekt | ▶ Werkzeug tauschen |
| Status LED: Dauerlicht Rot nach Einschalten | Initialisierung des Moduls fehlgeschlagen | ▶ Akku neu stecken ▶ Werkzeug neu starten |
| | Modul defekt | ▶ Modul tauschen |
| Status LED: Aus nach erfolgreicher Initialisierung | Spannungsversorgung nicht mehr aktiv | ▶ Startschalter am Werkzeug betätigen |

POWER TOOLS SALES & SERVICE CENTERS

Please note that all locations may not service all products.

Contact the nearest Cleco® Sales & Service Center for the appropriate facility to handle your service requirements.



Sales Center



Service Center

NORTH AMERICA | SOUTH AMERICA

DETROIT, MICHIGAN

Apex Tool Group
2630 Superior Court
Auburn Hills, MI 48236
Phone: +1 (248) 393-5644
Fax: +1 (248) 391-6295

LEXINGTON,

SOUTH CAROLINA  
Apex Tool Group
670 Industrial Drive
Lexington, SC 29072
Phone: +1 (800) 845-5629
Phone: +1 (919) 387-0099
Fax: +1 (803) 358-7681

MEXICO

Apex Tool Group
Vialidad El Pueblito #103
Parque Industrial Querétaro
Querétaro, QRO 76220
Mexico
Phone: +52 (442) 211 3800
Fax: +52 (800) 685 5560

EUROPE | MIDDLE EAST | AFRICA

FRANCE

Apex Tool Group SAS
25 Avenue Maurice Chevalier - ZI
77330 Ozoir-La-Ferrière
France
Phone: +33 1 64 43 22 00
Fax: +33 1 64 43 17 17

GERMANY

Apex Tool Group GmbH
Industriestraße 1
73463 Westhausen
Germany
Phone: +49 (0) 73 63 81 0
Fax: +49 (0) 73 63 81 222

HUNGARY

Apex Tool Group
Hungária Kft.
Platánfa u. 2
9027 GyőrHungary
Phone: +36 96 66 1383
Fax: +36 96 66 1135

ASIA PACIFIC

AUSTRALIA

Apex Tool Group
519 Nurigong Street, Albury
NSW 2640
Australia
Phone: +61 2 6058 0300

CHINA

Apex Power Tool Trading
(Shanghai) Co., Ltd.
2nd Floor, Area C
177 Bi Bo Road
Pu Dong New Area, Shanghai
China 201203 P.R.C.
Phone: +86 21 60880320
Fax: +86 21 60880298

INDIA

Apex Power Tool Trading
Private Limited
Gala No. 1, Plot No. 5
S. No. 234, 235 & 245
Indialand Global
Industrial Park
Taluka-Mulsi, Phase I
Hinjawadi, Pune 411057
Maharashtra, India
Phone: +91 020 66761111

JAPAN

Apex Tool Group Japan
Korin-Kaikan 5F,
3-6-23 Shibakoen, Minato-Ku,
Tokyo 105-0011, JAPAN
Phone: +81-3-6450-1840
Fax: +81-3-6450-1841

KOREA

Apex Tool Group Korea
#1503, Hibrand Living Bldg.,
215 Yangjae-dong,
Seocho-gu, Seoul 137-924,
Korea
Phone: +82-2-2155-0250
Fax: +82-2-2155-0252

Cleco

Apex Tool Group, LLC

Phone: +1 (800) 845-5629

Phone: +1 (919) 387-0099

Fax: +1 (803) 358-7681

www.ClecoTools.com

www.ClecoTools.de