

4

3

2

1

1
REV
SH11268
DWG. NO.

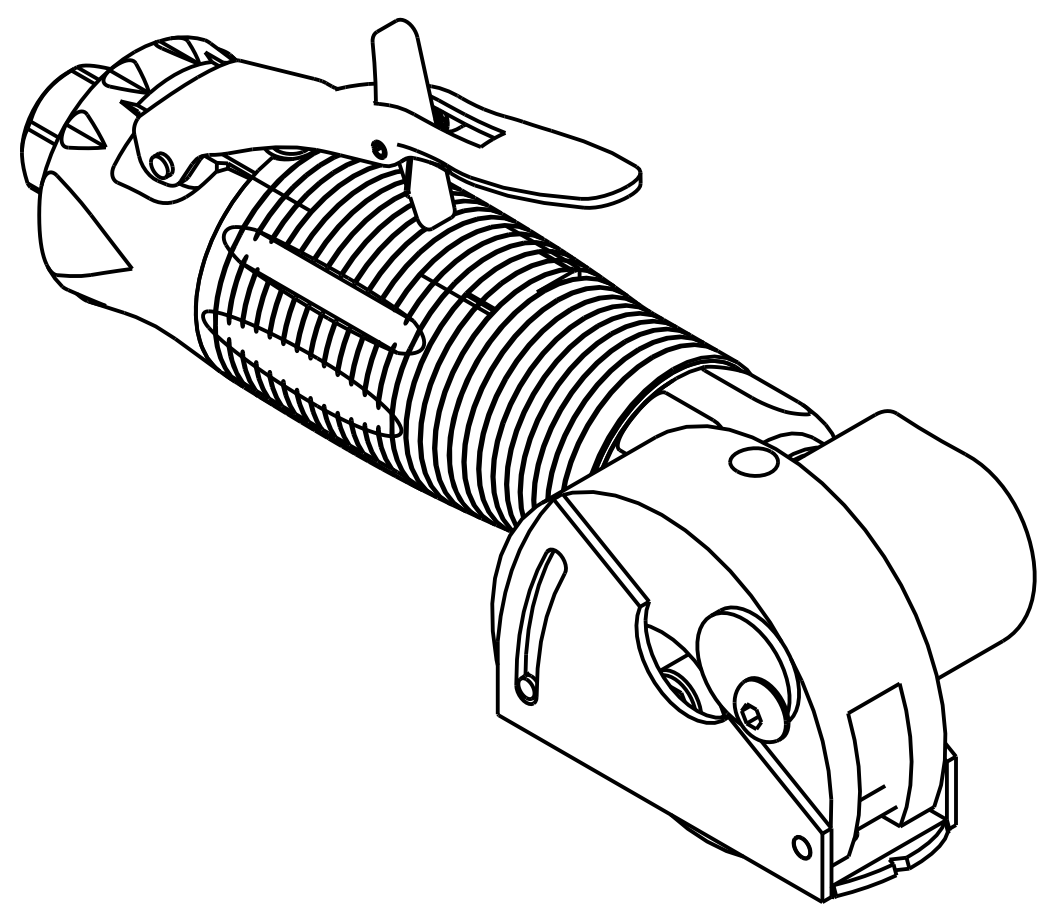
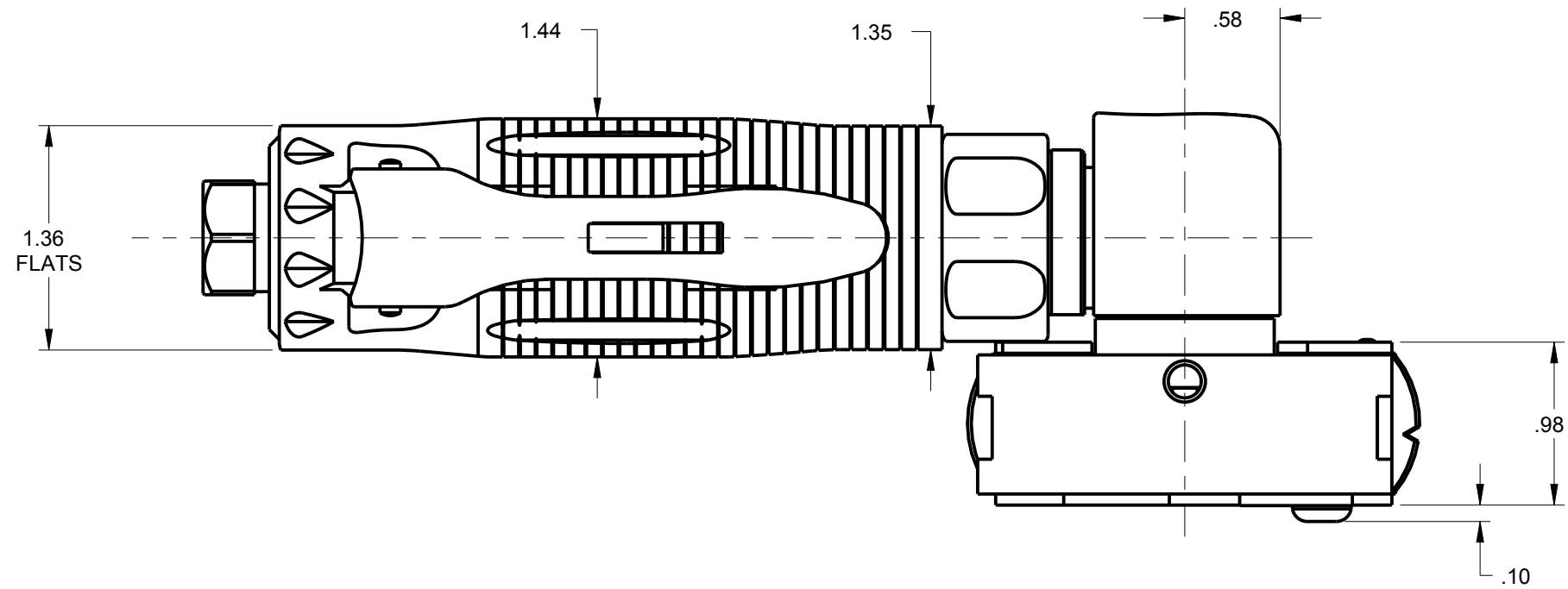

C

C

B

B

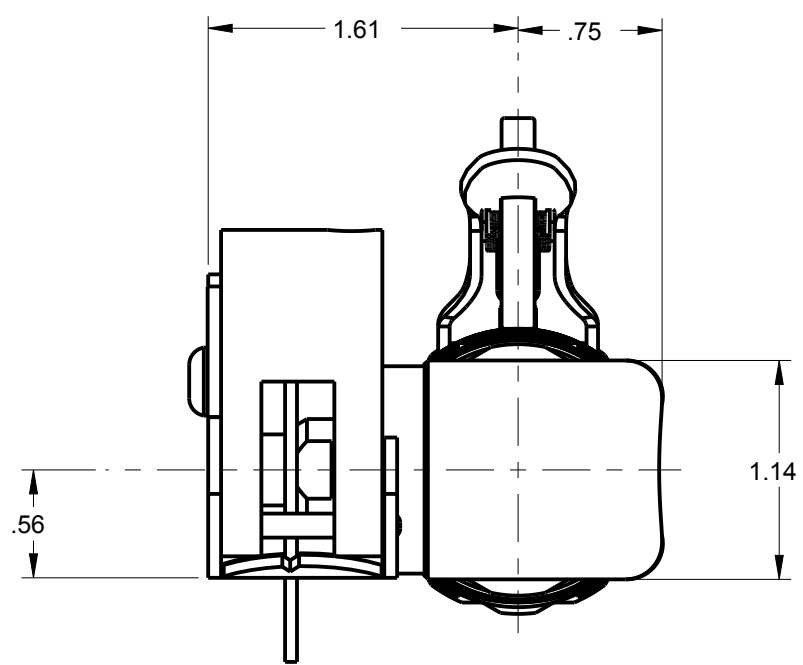
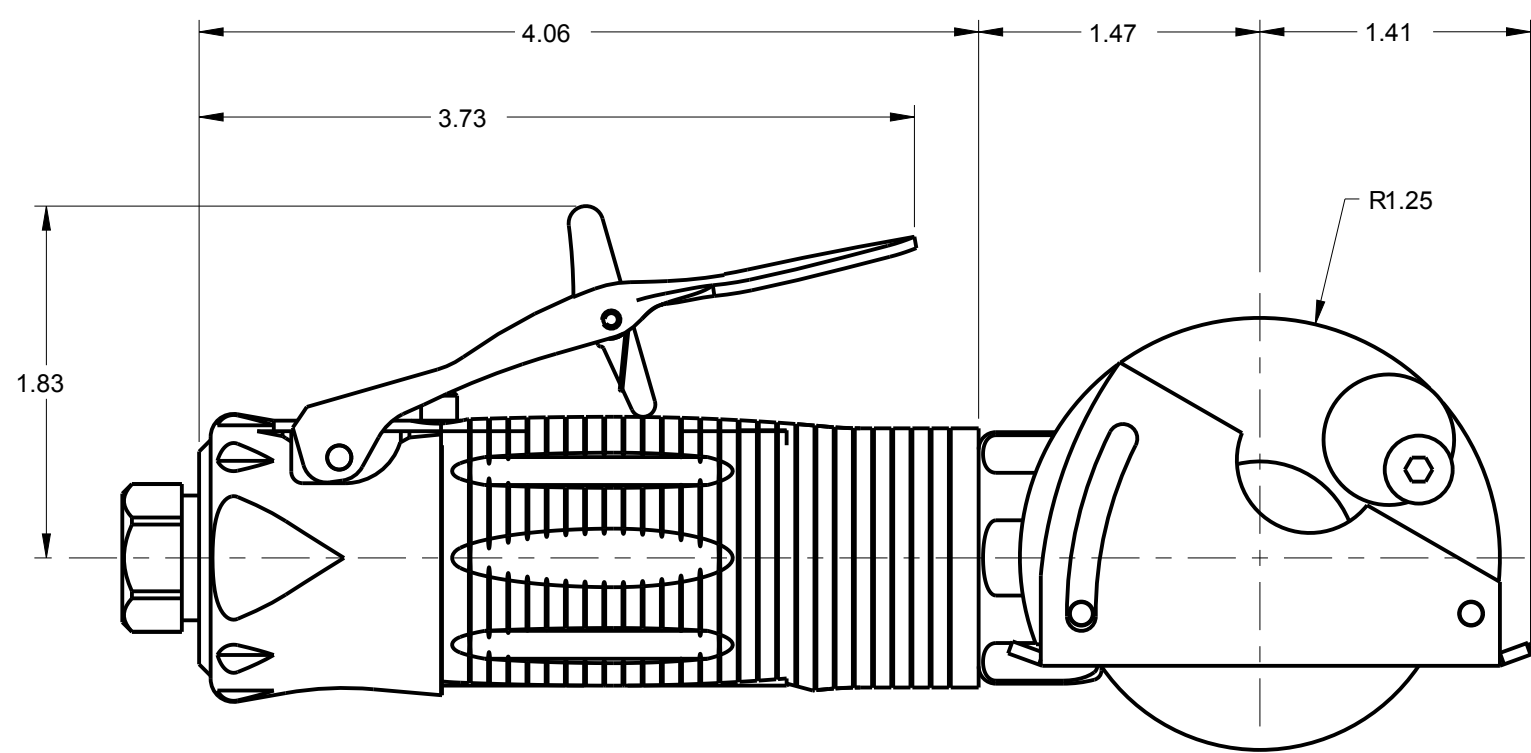

A

A

This document contains confidential and trade secret information which is the property of Apex Tool Group and receipt or possession does not convey any rights to loan, sell, or otherwise disclose said information. Reproduction or use of said information for any purpose other than that in connection with which said information was supplied may not be made without express written permissions of Apex Tool Group. This document is to be returned to Apex Tool Group upon request and in all events upon completion of the purpose for which it is loaned.

UNLESS OTHERWISE SPECIFIED: TWO PLACE DECIMALS ± .01, THREE PLACE DECIMALS ± .005, FOUR PLACE DECIMALS ± .0005
 MACHINING SURFACES. GEOMETRIC SYMBOLS PER ANSI Y14.5, MACHINE FILLETS .015 MAX, BREAK SHARP EDGES .015 MAX
 ANGULAR SURFACES TO BE TRUE WITHIN ± 1°, FEATURES ON COMMON C TO BE CONCENTRIC WITHIN .010 TOTAL

ZONE	REV	REVISION	DATE	BY

		DESCRIPTION	
MATERIAL		OUTLINE DRAWING	
ASSEMBLY		12S1207-02	
HEAT TREAT		SAW	
HARDNESS		DRAWN BY	
FINISH		REH	9/25/12
SIMILAR TO		DWG SIZE	SHEET
12S1207-02		C	1 OF 1
PART NO.		REV. DATE	REV
12S1207-02			1
DRAWING NO.		SH11268	

4

3

2

1