

Instruction Manual  
P1994BA/EN  
2014-06

# Cleco<sup>®</sup>

## 55PHH

Pulse nutsetter without shutoff



For additional product information visit our website at <http://www.apexpowertools.eu>

# Notes on this Instruction Manual

The original language of this instruction manual is German.

This instruction manual

- provides important instructions for safe and effective operation.
- It describes the function and operation of the pulse nutsetter (hereafter referred to simply as 55PHH).
- It serves as a reference work for technical data, service intervals and spare part orders.
- It points out options.

## Secondary information

P2204BA          Instruction Manual Oil filling unit

## In the text

55PHH          stands for all styles of the pulse nutsetter described here.

→                identifies instructions to be followed.

•                identifies lists.

<...>          identifies an index, see 8 Spare parts, page 25.

## In graphics



identifies movement in a direction.



identifies function and force.

In graphic illustrations:

If not absolutely essential, 55PHH (air from bottom) is illustrated.

## Model Key

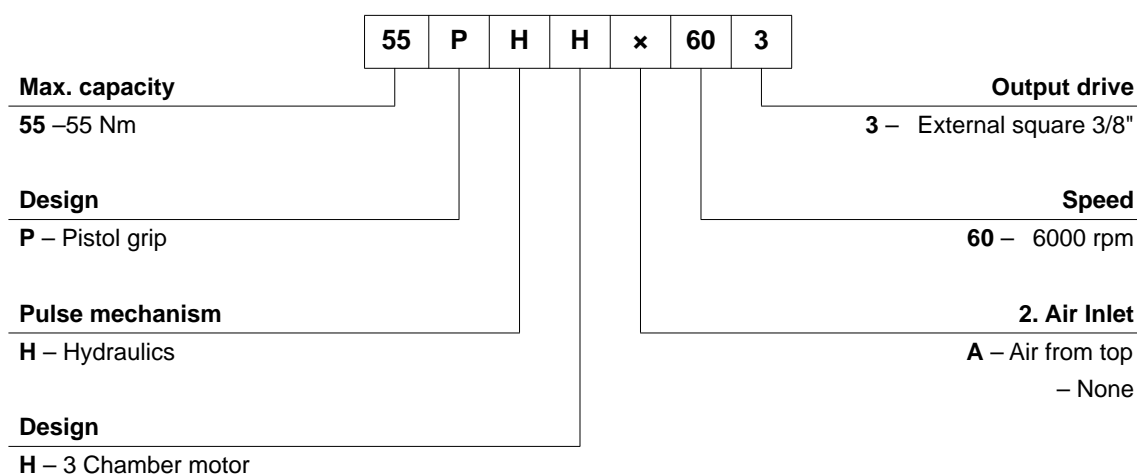

## Disclaimer:

Apex Tool Group reserves the right to modify, supplement or improve the document or the product without prior announcement. This document may not be reproduced in any way, shape or form, in full or parts thereof, or copied to another natural or machine readable language or to a data carrier, whether electronic, mechanical, optical or otherwise without the express permission of Apex Tool Group.

# Contents

<b>1</b>	<b>Safety</b>	<b>5</b>
1.1	Warnings and notes.....	5
1.2	Basic requirements for safe working practices.....	5
1.3	Operator training .....	6
1.4	Personal protective equipment.....	6
1.5	Designated use .....	6
1.6	Noise and vibrations.....	6
<b>2</b>	<b>Items supplied</b>	<b>7</b>
<b>3</b>	<b>Product description</b>	<b>7</b>
3.1	Operation and functional elements.....	7
3.2	Options .....	8
<b>4</b>	<b>Before initial operation</b>	<b>8</b>
4.1	Air supply .....	8
4.2	Change air inlet: top / bottom (only on 55PHHA) .....	9
4.3	Connect the tool .....	9
4.4	Setting up the tool .....	10
4.5	Troubleshooting.....	11
<b>5</b>	<b>Maintenance</b>	<b>13</b>
5.1	Service schedule .....	13
5.2	Fill reserve oil .....	14
5.3	Complete oil filling .....	16
<b>6</b>	<b>Disassembly instructions</b>	<b>19</b>
6.1	Remove motor unit.....	19
6.2	Remove throttle valve.....	20
6.3	Remove pulse unit.....	20
<b>7</b>	<b>Assembly instructions</b>	<b>20</b>
7.1	Install motor unit.....	21
7.2	Install pulse unit.....	23
<b>8</b>	<b>Spare parts</b>	<b>25</b>
8.1	Pistol grip 55PHH... ..	26
8.2	Pistol grip 55PHHA... ..	28
8.3	Motor unit .....	30
8.4	Pulse unit.....	32
8.5	Equipment order list .....	34
<b>9</b>	<b>Technical data</b>	<b>35</b>
9.1	Dimensions 55PHH... in mm.....	35
9.2	Dimensions 55PHHA... in mm .....	36

9.3	Performance Data .....	37
9.4	Ambient conditions .....	37
<b>10</b>	<b>Service</b>	<b>37</b>
<b>11</b>	<b>Disposal</b>	<b>37</b>

# 1 Safety

## 1.1 Warnings and notes

Warning notes are identified by a signal word and a pictogram:

- The signal word describes the severity and the probability of the impending danger.
- The pictogram describes the type of danger.

### WARNING!



**Potentially hazardous** situation for health and safety.  
If this warning is not observed, death or serious injury may occur.

### CAUTION!



**Potentially hazardous** situation to health and safety, or risk of material and environmental damage. If this warning is not observed, injuries or damage to materials or the environment could occur.

### NOTE



**General notes**  
include application tips and particularly useful information but no hazard warnings.

## 1.2 Basic requirements for safe working practices

All instructions must be read carefully. Failure to observe the instructions listed below can result in serious injuries.

### CAUTION!



- Work with a maximum working pressure of 101.5 psi (700 kPa) (measured at the air inlet tube of the tool).
- Before initial operation, check that the suspension bail is properly fastened to the balancer.
- 55PHHA: Before using the air inlet from above, make sure that the pipe plug is correctly fitted in the lower air inlet.
- If you hear unusual noises or vibrations, switch off the tool immediately.  
Cut off the air supply immediately.
- Before carrying out repairs, adjusting the torque or replacing screw bits, disconnect the tool from the compressed air line.
- The compressed air line must be depressurized before disconnecting it.
- Never use the air hose to hold, raise or lower the tool.
- Air hoses, the suspension bail and fittings must be regularly checked for damage and wear. Renew as necessary.
- Always carry out assembly according to Chapter 8 Spare parts, page 25.
- Use only accessory parts authorized by Apex Tool Group (see product catalog).
- Only use screw bits for machine-controlled fastening tools.
- Make sure that the screw bits are securely inserted.
- Inspect screw bits for visible damage and cracks.  
Renew damaged bits immediately.
- The operation, maintenance and repair conditions set forth in the instruction manual must be observed.
- Follow generally valid and local safety and accident prevention rules.

### 1.3 Operator training

Users must be given instruction in the correct usage of the tool. The operator must make the Operating Manual accessible to users and make sure that the users have read and understood it. The tool may only be connected, used, serviced and repaired by qualified persons. Repairs to the tool may only be performed by authorized personnel.

### 1.4 Personal protective equipment



- Wear protective goggles to protect against sprays of metal splinters and fluids.
- Wear gloves to protect against skin irritation in case of direct contact with oil.



Danger of injury by being wound up in and caught by machinery



- Wear a hairnet.
- Wear close-fitting clothing.
- Do not wear jewelry.



Sound level in the area of the user > 80 dB(A), danger of hearing damage

- Wear hearing protection.

### 1.5 Designated use

The 55PHH is designed exclusively for fastening and releasing threaded fasteners.

- Do not use it as a hammer.
- Do not open it or modify it structurally.
- Do not use it in areas where there is a risk of explosion.

### 1.6 Noise and vibrations

#### Sound pressure level $L_p$ in accordance with DIN EN ISO 15744

Idle for  $n \leq 6000$  rpm < 80 dB(A)

#### Vibration values in accordance with DIN EN ISO 28927-2

55PHH:

Idle ahv for  $n \leq 6000$  rpm < 1.8 m/s<sup>2</sup>

Pulses ahv < 4.0 m/s<sup>2</sup>

55PHHA:

Idle ahv for  $n \leq 6000$  rpm < 1.8 m/s<sup>2</sup>

Pulses ahv < 4.5 m/s<sup>2</sup>

Pulses ahv 55PHHA + absorber (on request) < 2.5 m/s<sup>2</sup>

With vibration levels ahv > 2.5 m/s<sup>2</sup>, the exposure time is to be reduced. See example

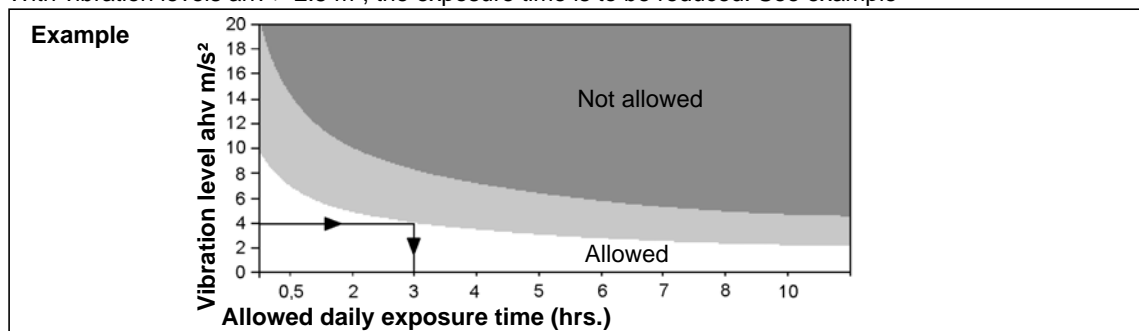

## 2 Items supplied

Check shipment for transit damage and ensure that all items have been supplied:

- 1 55PHH
- 1 This instruction manual
- 1 Declaration of Conformity
- 1 Hex wrench (WAF 2)

## 3 Product description

### 3.1 Operation and functional elements

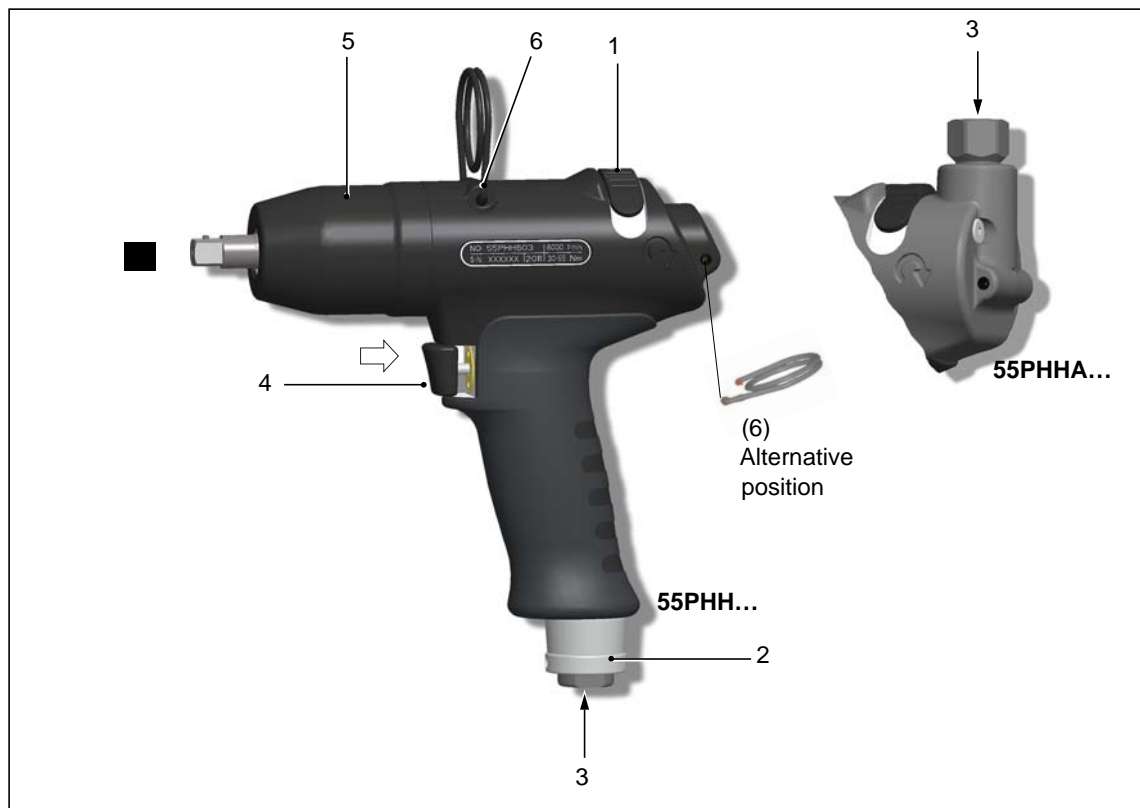

Item.	Designation
1	Reverse switch
2	Exhaust air throttle: torque adjustment, see Abb. 4-1 , page 10
3	Air inlet
4	Start button
5	Reserve oil, see 5.2 Fill reserve oil, page 14
6	Suspension bail

## 3.2 Options

	Protective sleeve Order No. 937449PT – 55PHH... Order No. 937444PT – 55PHHA...
	Vibration absorber Order No. 935965 – 55PHHA...
	Quick change chuck adapter Order No. 935472

## 4 Before initial operation

### 4.1 Air supply

Parameter	Data
Air hose	Inner diameter 3/8" (ø 9.5 mm), maximum length 5 m
Air inlet	1/4" NPT, inner diameter ≥7.5 mm

- Make sure that the pressure before the pressure regulator is at least 0.5 bar higher than the required inlet air pressure at the tool.
- Keep the inside of the air hose free of residue; clean it if necessary.

#### Air quality

In accordance with ISO 8573-1, quality class 2.4.3, compressed air must be dry and clean.

Parameter	Data
Working pressure range	400 ... 700 kPa
Max. dew point	+ 10° C

#### Air preparation units

Our recommendation: air preparation units (filters, regulators, lubricators) should be installed

Device	Explanation
Filter	Retention of particles > 15 micrometers. Removes more than 90% of condensation.
Regulator	To attain constant work results, the working pressure must be kept constant for every individual tool.



Device	Explanation
Lubricator	<p>Compressed air requires a small amount of oil and is orientated to the air consumption of the tool.</p> <p>→ Calculate the time (T) between two drops of oil and make the following settings at the lubricator:</p> $T = \frac{60}{F \times L}$ <p>F = Factor for pulse nutsetter = 2 L = Air consumption of tool at idle m<sup>3</sup>/min (see performance data for pulse shut-off nutsetter)</p>

#### Oils according to DIN 51524 / ISO 3498

Order no.	Packaging unit Liter	Name	ARAL	BP	elf	ESSO	INA	Mobil	Klüber	SHELL
933090	2	HL32	Aralub EE 100	Energol HL 32	Polyelis 32 Olna 32	Nuto H 32	Hydraol 32A	D.T.E.Oil Light Vactra Oil Light	Crukolan 32	Molina 32 Molina 22

## 4.2 Change air inlet: top / bottom (only on 55PHHA)

When delivered, the air inlet is at the BOTTOM and sealed with a screw plug. To change the air supply from top to bottom:

- Remove the air strainer from the air inlet at the TOP (do not discard), see 8.2 Pistol grip 55PHHA..., page 28, Detail X.
- Remove screw plug from BOTTOM. When doing this, counterhold with wrench (WAF 17).
- Seal the air inlet at TOP with screw plug in accordance with specifications.

## 4.3 Connect the tool

### CAUTION!



The air hose can come off by itself and whip around uncontrollably.

- Shut off the compressed air before making the connection.
- Connect the tool to the compressed air line.  
Maximum screwing-in torque = 40 Nm. Reaction torque at flat end. Counterhold with wrench (WAF 17).
- Activate compressed air: 620 kPa.

### 4.3.1 Testing

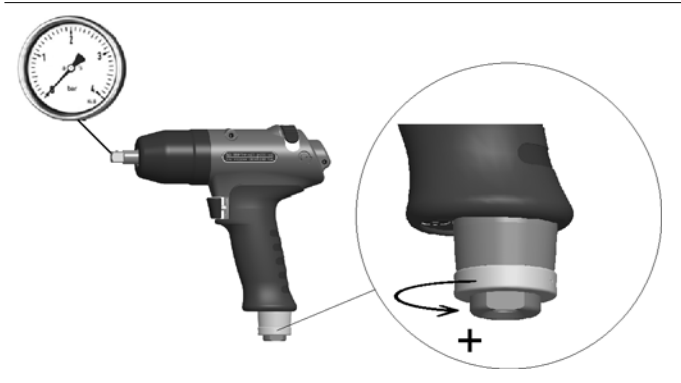

- Fully open exhaust air throttle anti-clockwise.
- Check speed at output drive: >6000 rpm

## 4.4 Setting up the tool

The tool must be configured for the desired rundown.

### 4.4.1 Setting the torque

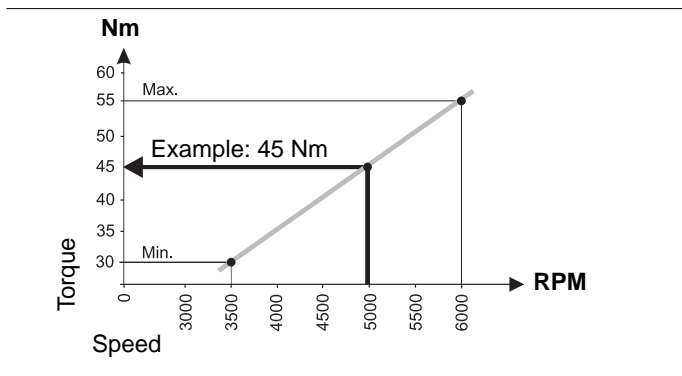

Settings example:

Tightening: 45 Nm

Screw M10: 8.8

- Set speed to approximately 5000 rpm

Abb. 4-1

- To achieve better repeat precision for fastenings, throttle the speed back at the tool until the required torque is achieved at the end of rotation of the fastening. On hard to medium-hard screwed joints, this is achieved in 1 to 2 seconds. Longer fastening then does not result in higher torque.

### 4.4.2 Changing Torque

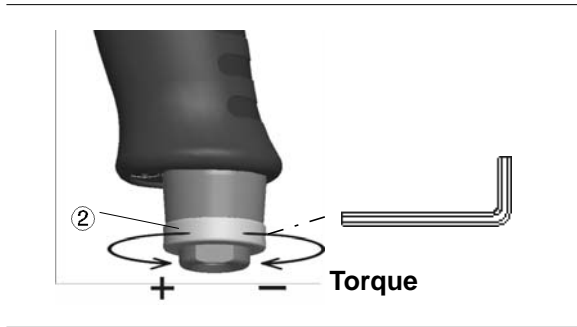

- Unscrew the threaded pin using the hex wrench (WAF 2).
- To reduce torque, turn the exhaust air throttle ② clockwise.
- To increase torque, turn the exhaust air throttle ② counter-clockwise.

Abb. 4-2

**NOTE**



The torque setting may be corrected when the compressed air is activated.

### 4.4.3 Checking torque

We recommend carrying out a *static* torque check by retightening the screwed joint.

- If the torque difference is too large, it may be necessary to change the torque setting. See 4.4.2 Changing Torque.
- If the setting has been changed, check the torque again.

When carrying out a *dynamic* measurement using a transducer adapter, also carry out a static test on the screwed joint, for example with a torque wrench (electronic).

## 4.5 Troubleshooting

Error	Possible causes	Measures and remedies
<b>Tool too strong</b>	Torque set too high	→ Reduce the torque setting, see 4.4.2 Changing Torque, page 11
<b>Tool too weak</b>	Working pressure too low	→ Check the cross section of the hose and coupling: Inner diameter 3/8" (ø 9.5 mm), maximum length 5 m → Increase the working pressure.
	Reverse button is not at the detent	→ Turn the reverse button to the detent
	Excessive transmission damping due to extension and worn socket.	→ Increase the speed, see 4.4.1 Setting the torque, page 10. → Use a shorter or more rigid extension. → Replace the socket
	Insufficient oil in the pulse unit (no pulse build-up)	→ See 5.2 Fill reserve oil, page 14
	Screen in the air inlet tube / muffler is dirty	→ Clean or replace parts

<b>Error</b>	<b>Possible causes</b>	<b>Measures and remedies</b>
<b>Accuracy insufficient</b>	Adapter parts	→ Replace adapter parts → Use extension and socket with guide diameter
	Pressure fluctuations in the air network	→ Use a pressure regulator
	Premature release of the start button	→ Keep start button pressed until nut-setter has stopped rotating
<b>Fastening time too long: &gt; 4 seconds</b>	Joint too soft; crush nuts, self-tapping screws	→ Increase the speed → Use a pulse nutsetter with a higher capacity.

## 5 Maintenance

**CAUTION!**

Danger of injury due to unintentional activation  
– before service, disconnect the tool from the compressed air supply.

### 5.1 Service schedule

Regular service reduces operating faults, repair costs and downtime.

Maintenance interval	Rundowns	Measures
<b>W1</b>	100.000	<ul style="list-style-type: none"> <li>→ Check the suspension bail for functional safety.</li> <li>→ Check the air hose for wear.</li> <li>→ Check the square on the output drive for wear.</li> <li>→ Check the air inlet for tight fit.</li> <li>→ Check the housing of the pulse unit for tight fit.</li> <li>→ Check the maximum idling speed.</li> <li>→ Check the reserve oil.</li> </ul>
<b>W2</b>	500.000	<ul style="list-style-type: none"> <li>→ Oil change, see 5.3 Complete oil filling, page 16.</li> <li>→ Motor service kit, see 3) Part of motor service kit K1 order no. 936169, page 27.</li> <li>→ Hydraulic service kit, see 3) Part of hydraulic service kit K2, order no. 936211, page 33.</li> <li>→ Replace muffler, filter.</li> </ul>
<b>W3</b>	1.000.000	<p>Check individual parts and replace if necessary</p> <ul style="list-style-type: none"> <li>→ Suspension bail</li> <li>→ Throttle valve</li> <li>→ Exhaust air throttle</li> <li>→ Motor</li> <li>→ Pulse unit</li> </ul>

This maintenance schedule uses values that are valid for most applications. For a specific maintenance interval, see 5.1.1 Calculating a customer-specific maintenance plan, page 14.

Implement a safety-related maintenance program that takes the local regulations for repair and maintenance for all operating phases of the tool into account.

### 5.1.1 Calculating a customer-specific maintenance plan

A service interval **W(1,2,3)** depends on the following factors:

Factor	Value assumed in 6.1, "Maintenance plan"	Description
<b>V</b>	V1 = 100,000 V2 = 500,000 V3 = 1,000,000	Number of rundowns after which a maintenance measure is prescribed by Apex Tool Group.
<b>T1</b>	1.8 seconds	Specific rundown time, measured in life and endurance tests.
<b>T2</b>	2 seconds	Actual rundown time, depending on the hardness of the joint.
<b>S</b>	1; 2; 3	Number of shifts per day.
<b>VS</b>	750	Number of rundowns per shift.

**T2, S** and **VS** are variable factors and can differ depending on the specific application.

Example for service interval **W2**:



After 500,000 rundowns (**V**),  
a specific rundown time of 1.8 seconds (**T1**)  
with an actual fastening time of 3 seconds (soft joint) and  
3 completed shifts per day and 750 rundowns per shift:

$$W(1, 2, 3) = \frac{V \times T_1}{T_2 \times S \times VS} \qquad W2 = \frac{500000 \times 1,8}{2 \times 3 \times 750} = 200\text{Tage}$$

You have to carry out the maintenance measures marked **W2** after an operating time of 200 days.

### 5.2 Fill reserve oil

If **X = 0** (see picture 2), the reserve oil is exhausted and must be refilled to guarantee a controlled process.

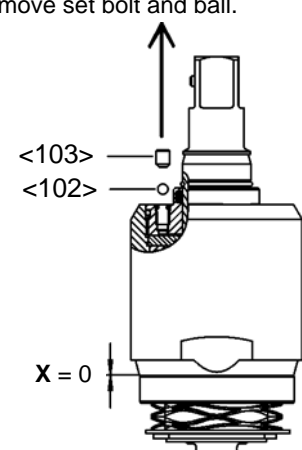
<p><b>1</b> → Remove pulse unit.</p> 	<p><b>2</b> → Remove set bolt and ball.</p> 
--	--

**3**

→ Align both ends as shown in the picture (internal equalization hole is opened).

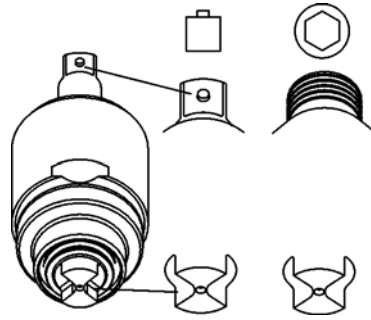

**4**

→ To avoid air pockets, fill the filling hole full of oil.

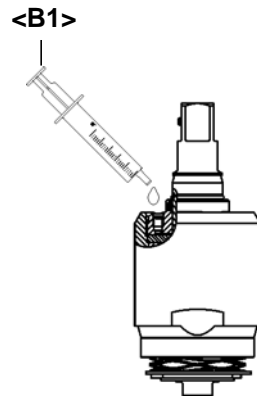

**5**

→ Position the injector so that it has a sealing effect and add reserve oil until distance **X** for spacer **<B2>** is achieved.

→ Maintain distance **X** and secure with **<B2>**.

→ Refit set bolt and ball.

→ Remove **<B2>**.

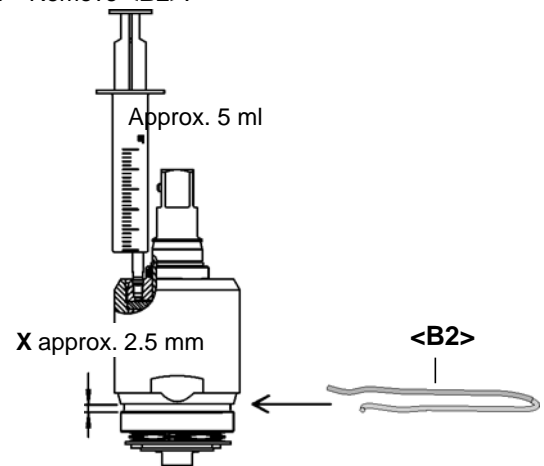

## 5.3 Complete oil filling

If no more pulses are generated, or if the pulse unit has been removed and refitted, the pulse unit must be completely refilled with oil:

Oil order No. 925715, ESSO-UNIVIS HVI26, approx. 2 liters, temperature  $20 \pm 5 \text{ }^\circ\text{C}$

**1**

→ Remove set bolt and ball

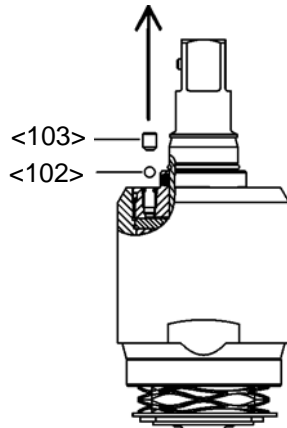

**2**

→ Align both ends of the pulse unit as shown in the picture (internal equalization hole is opened)

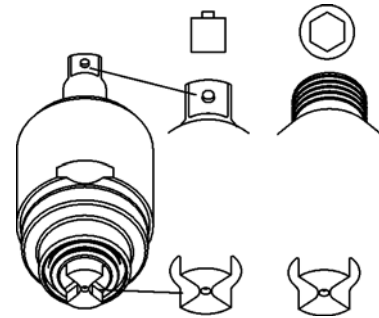

**3**

→ Use adapter ① to connect pulse unit to the quick disconnect coupling.

→ Close shutoff valve ②.

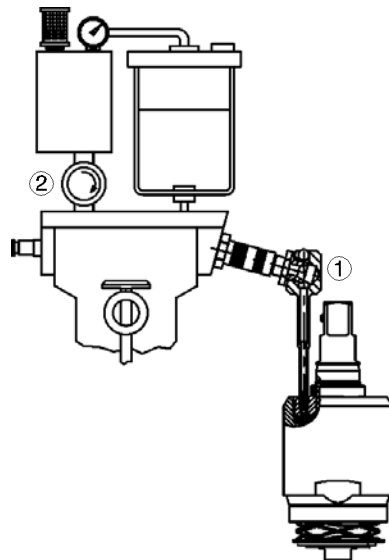

**4**

→ Set the working pressure to approx. 500 kPa.

→ Slowly open the shut-off valve all the way until the gauge shows a negative pressure of <math><10 \text{ mbar}</math> (-1 bar).

→ Wait approx. 2 minutes until the number of vacuum bubbles has reduced significantly.

→ Slowly close the shut-off valve. The gauge shows atmospheric pressure again. Missing oil will be pressed back into the pulse unit.

→ If necessary, repeat the last 3 rundown steps until bubbles are reduced practically to zero.





**5**

- Uncouple the pulse unit and unscrew the adapter.
- To avoid air pockets, fill the filling hole full of oil.

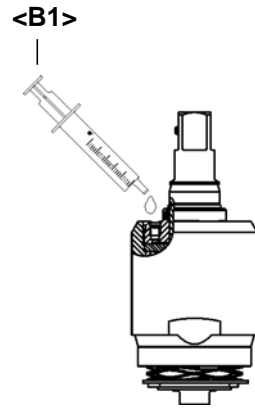
**6**

- Position the injector so that it has a sealing effect and add reserve oil until distance **X** for spacer <B2> is achieved.
- Maintain distance **X** and secure with <B2>.
- Refit set bolt and ball.
- Remove <B2>.

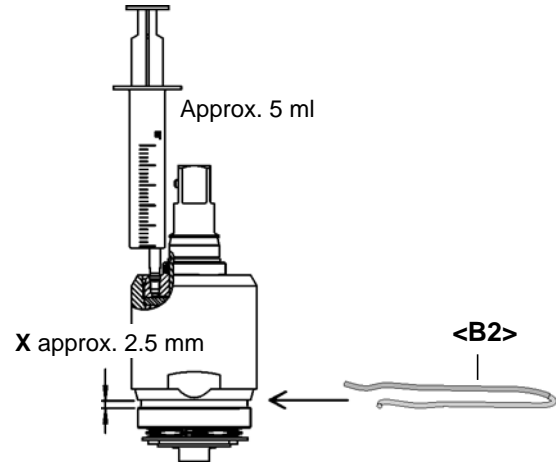
**NOTE**

Small air bubbles that become visible due to the high pressure during filling do not mean that the pulse unit is leaking. This will not negatively affect the filling result.

Empty side

# 6 Disassembly instructions

<...> Please refer to 8 Spare parts, page 25 and 8.5 Equipment order list, page 34

## 6.1 Remove motor unit

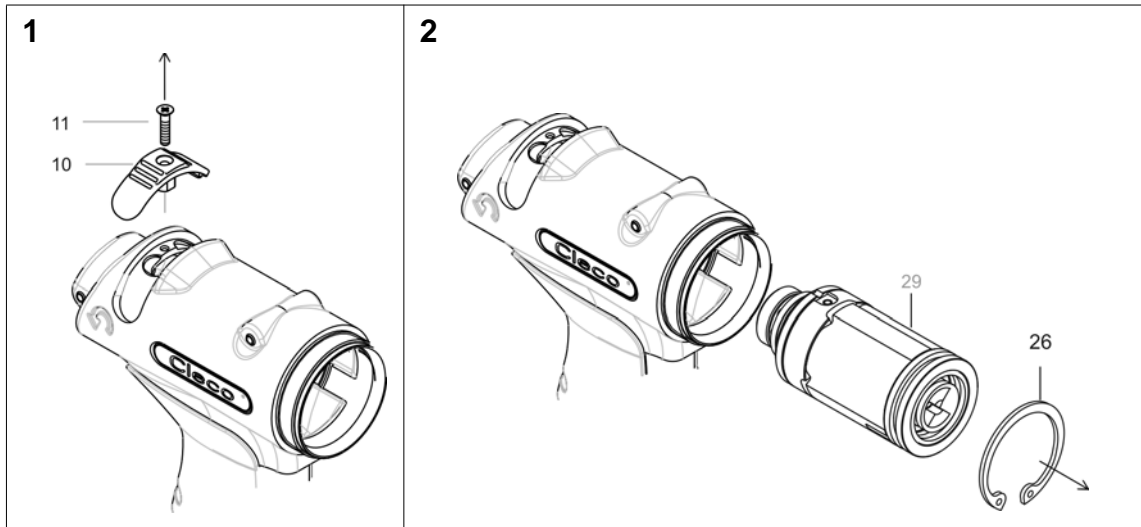

### Changing blades

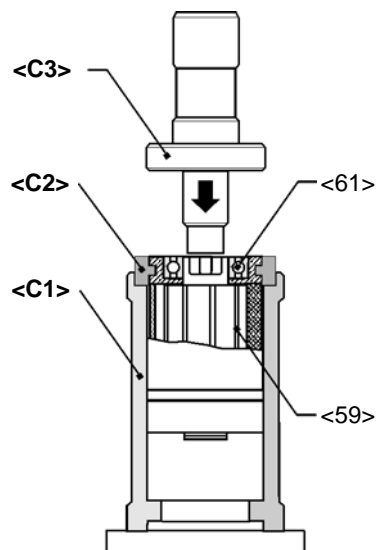

### Changing bearings / rotor

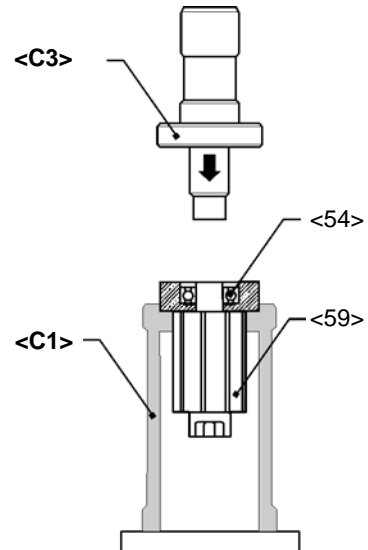

## 6.2 Remove throttle valve

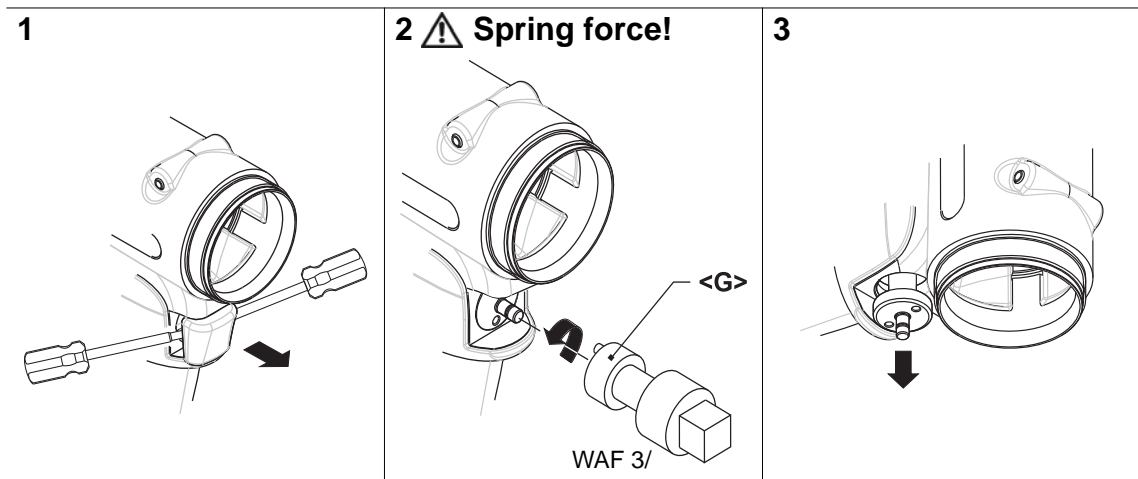

## 6.3 Remove pulse unit



Abb. 6-1

**CAUTION!**

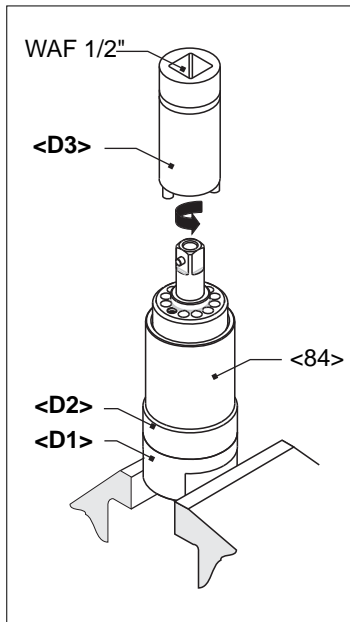

Skin irritation in case of direct contact with oil.  
Wear protective gloves.

**CAUTION!**



Hydraulic blade is under spring pressure!  
Wear protective goggles.

**NOTE**



Permitted only if filling is guaranteed with oil filling device, see 5.3 Complete oil filling, page 16. Pulse unit must have cooled down to room temperature.

# 7 Assembly instructions

<...> Please refer to 8 Spare parts, page 25 and 8.5 Equipment order list, page 34

## 7.1 Install motor unit

---

### CAUTION!



- Only perform installation in accordance with exploded drawing, see 8.3 Motor unit, page 30. Incorrect installation can lead to uncontrolled reactions, e.g. unexpected start-up or parts being hurled out.
  - Tighten all screwed joints of the tool carefully, according to the specifications.
- 

### NOTE



To prevent damage, lubricate the gaskets and O-rings using grease (order no. 914392) before assembly.

### 7.1.1 Install rotor cover

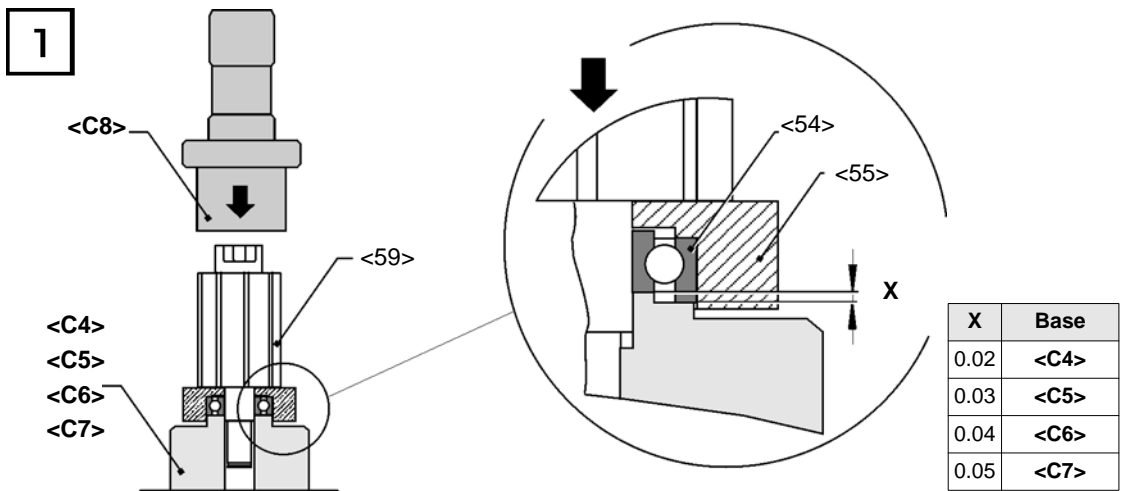

1. Press <59> in with <C4>, see X.

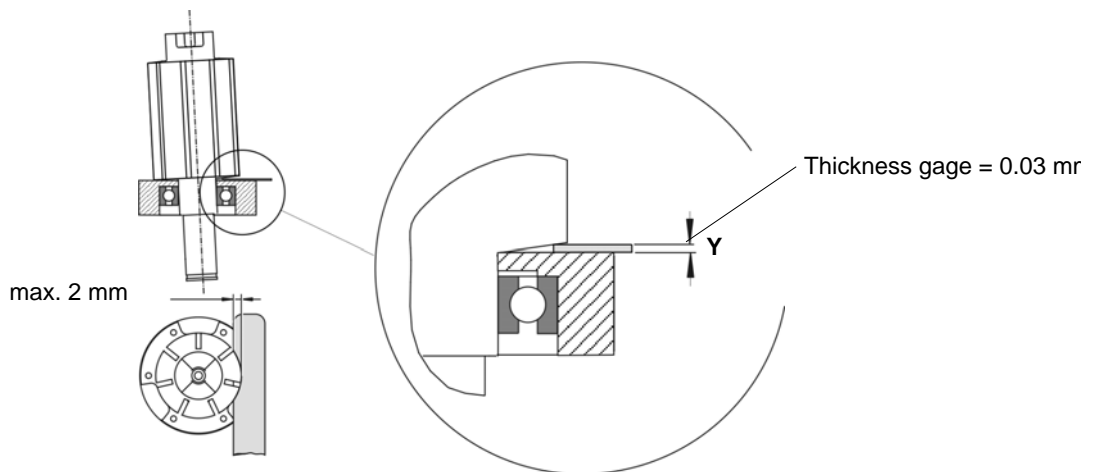

2. **Examine Y** with thickness gage. If dimension > Y, step 1 with support <C5>, <C6>, <C7> repeat.

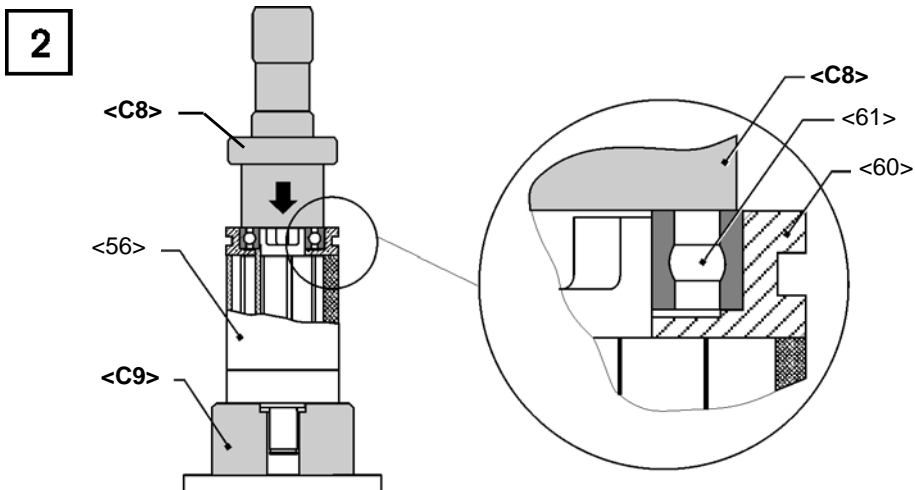

Press <61> in with <C8>.

## 7.2 Install pulse unit

**NOTE**



To prevent damage, lubricate the gaskets and O-rings using grease (order no. 914392) before assembly.

### 7.2.1 Assembling the hydraulic blades

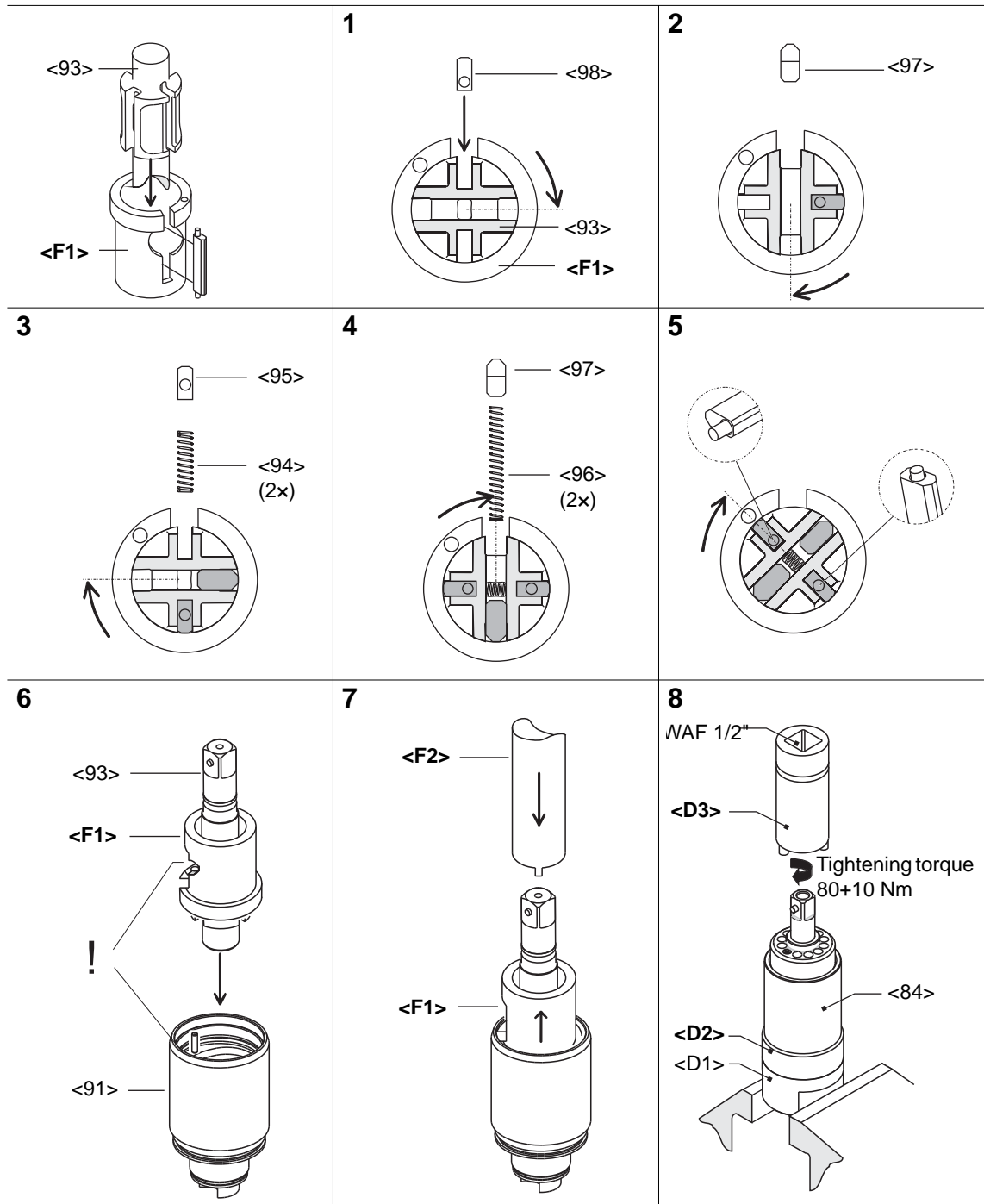





## 8 Spare parts

### NOTE



Only Cleco original spare parts should ever be used. Using other parts could lead to inferior performance and increased maintenance requirements. If non-original spare parts are installed, the tool manufacturer is entitled to declare all warranty obligations for null and void.

We would be glad to prepare a special quote for you for spare and wear parts.  
Please give the following data:

- Tool model
- Number of tools
- Number of rundowns per day or per shift
- Turn-off torque
- Fastening time per rundown

### 8.1 Pistol grip 55PHH...

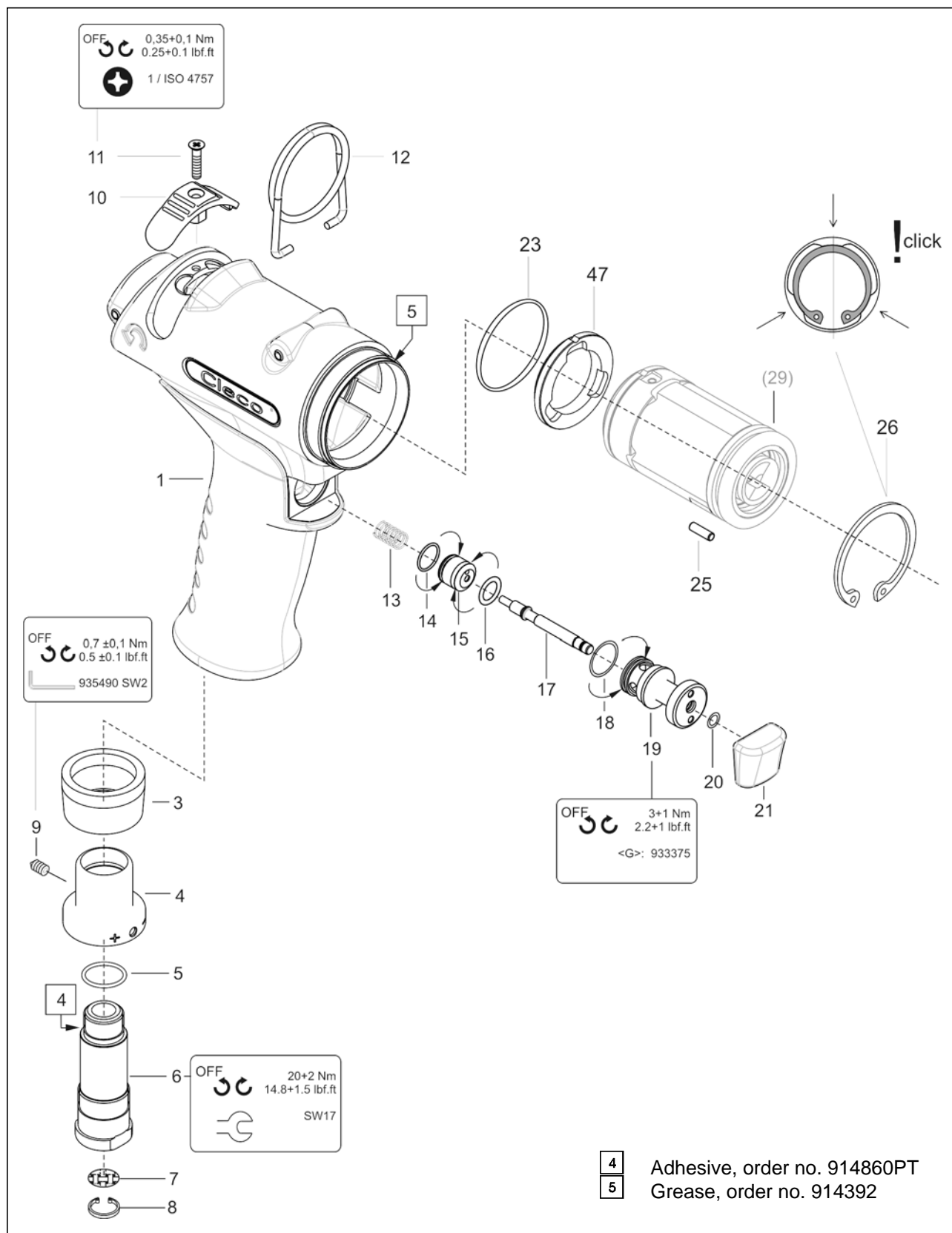

Index	1)	2)	3)	Description	4)
1	936161	1		pistol grip housing asm.	
3	935438	1	K1	muffler	
4	935434	1		exhaust air throttle	
5	922660	1	K1	o-ring	16,X1,5
6	935437	1		air inlet	
7	905031	1	K1	screen	
8	905599	1	K1	circlip	11,X1, IR
9	S905998	1	K1	set bolt	M 4X4
10	935422	1		reverse button	
11	931792	1		countersunk screw	M 3X 14
12	935442	1		suspension ball	
13	935482	1	K1	compression spring	0,5 X 6,X 23,8
14	539188	1	K1	o-ring	9,X1,
15	935441	1		piston	
16	504970	1	K1	o-ring	7,65X1,78
17	935440	1		control push rod	
18	912150	1	K1	o-ring	12,X1,
19	935439	1		plug	
20	905086	1	K1	o-ring	4,X1,
21	935446	1		push-button	
23	926567	1	K1	o-ring	35, X1,5
25	916772	1	K1	needle roller	3,X9,8
26	917808	1	K1	circlip	38,X1,5IR
47	936222	1		air distributor	

1)Order no.

2)Quantity

3) Part of motor service kit K1 order no. 936169

4)Dimensions

## 8.2 Pistol grip 55PHHA...

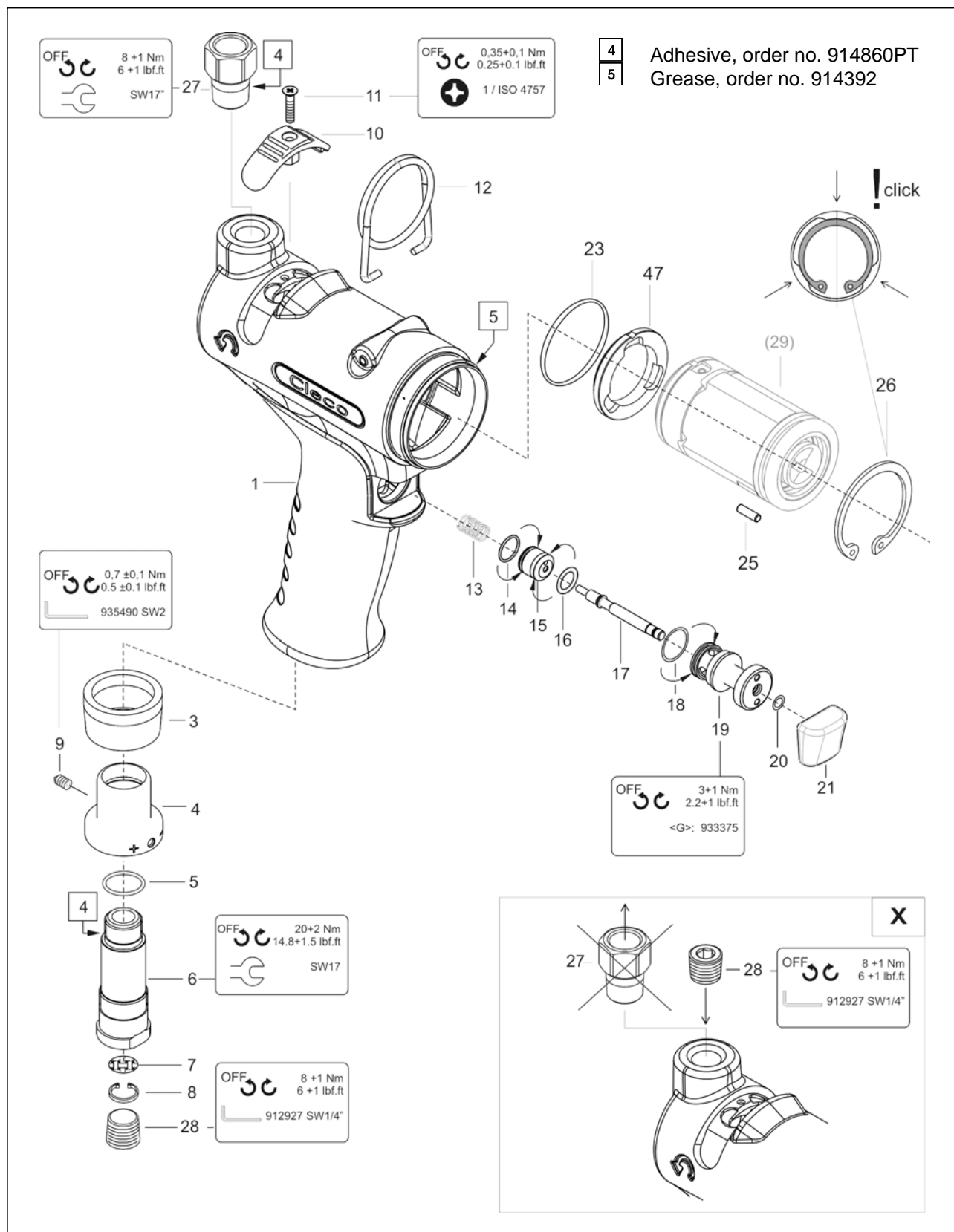

Index	1)	2)	3)	Description	4)
1	936165	1		pistol grip housing asm.	
3	935438	1	K1	muffler	
4	935434	1		exhaust air throttle	
5	922660	1	K1	o-ring	16,X1,5
6	935437	1		air inlet	
7	905031	1	K1	screen	
8	905599	1	K1	circlip	11,X1, IR
9	S905998	1	K1	set bolt	M 4X4
10	935422	1		reverse button	
11	931792	1		countersunk screw	M 3X 14
12	935442	1		suspension ball	
13	935482	1	K1	compression spring	0,5 X 6,X 23,8
14	539188	1	K1	o-ring	9,X1,
15	935441	1		piston	
16	504970	1	K1	o-ring	7,65X1,78
17	935440	1		control push rod	
18	912150	1	K1	o-ring	12,X1,
19	935439	1		plug	
20	905086	1	K1	o-ring	4,X1,
21	935446	1		push-button	
23	926567	1	K1	o-ring	35, X1,5
25	916772	1	K1	needle roller	3,X9,8
26	917808	1	K1	circlip	38, X1,5 IR
27	935727	1		air strainer	
28	931771	1		screwed plug	1/4 NPT
47	936222	1		air distributor	

1)Order no.

2)Quantity

3) Part of motor service kit K1 order no. 936169

4)Dimensions

### 8.3 Motor unit

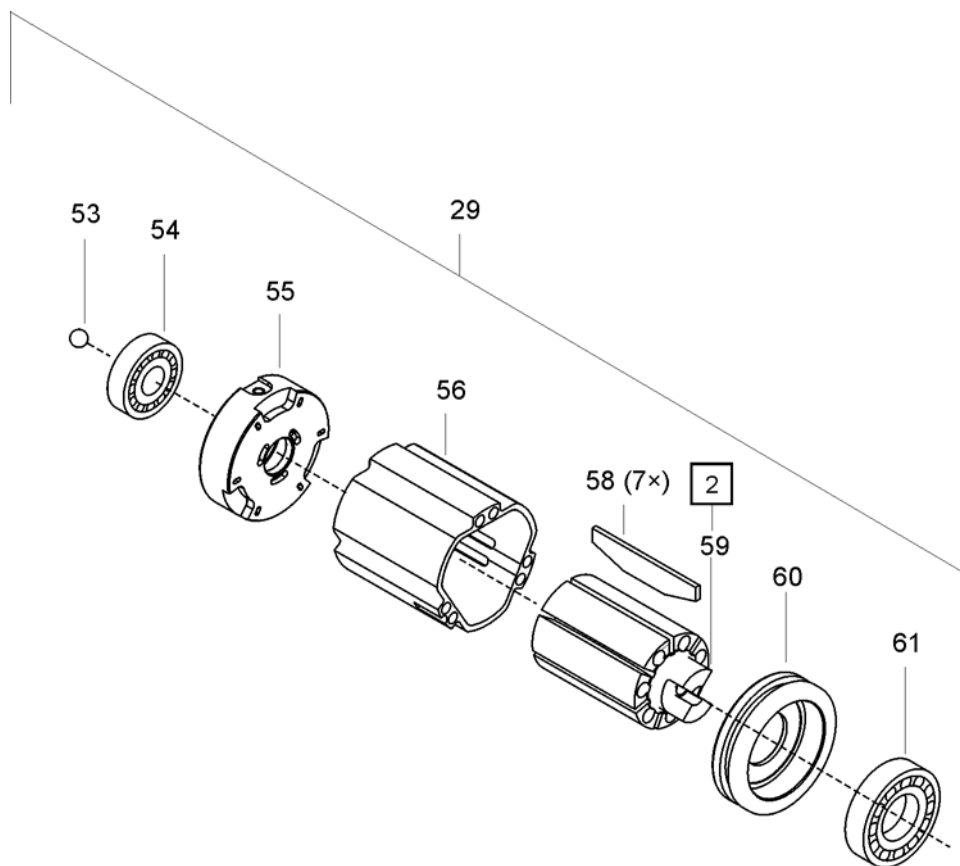

2 Axial clearance, see 7.1.1 Install rotor cover, page 22

Index	1)	2)	3)	Description	4)
29	936167	1		motor unit	
53	936265	1	K1	ball	6,35 POM
54	936243	1	K1	ball bearing	12,X 24,X 6; C4
55	936233	1		rotor cover	
56	935418	1		rotor cylinder	
58	935436	7	K1	blade	L38,0 D1,5 H 8,0
59	936254	1		rotor asm.	
60	935433	1		rotor cover	
61	S909814	1	K1	ball bearing	15,X 28,X 7,

1)Order no.

2)Quantity

3)Part of motor service kit K1 order no. 936169

4)Dimensions

### 8.4 Pulse unit

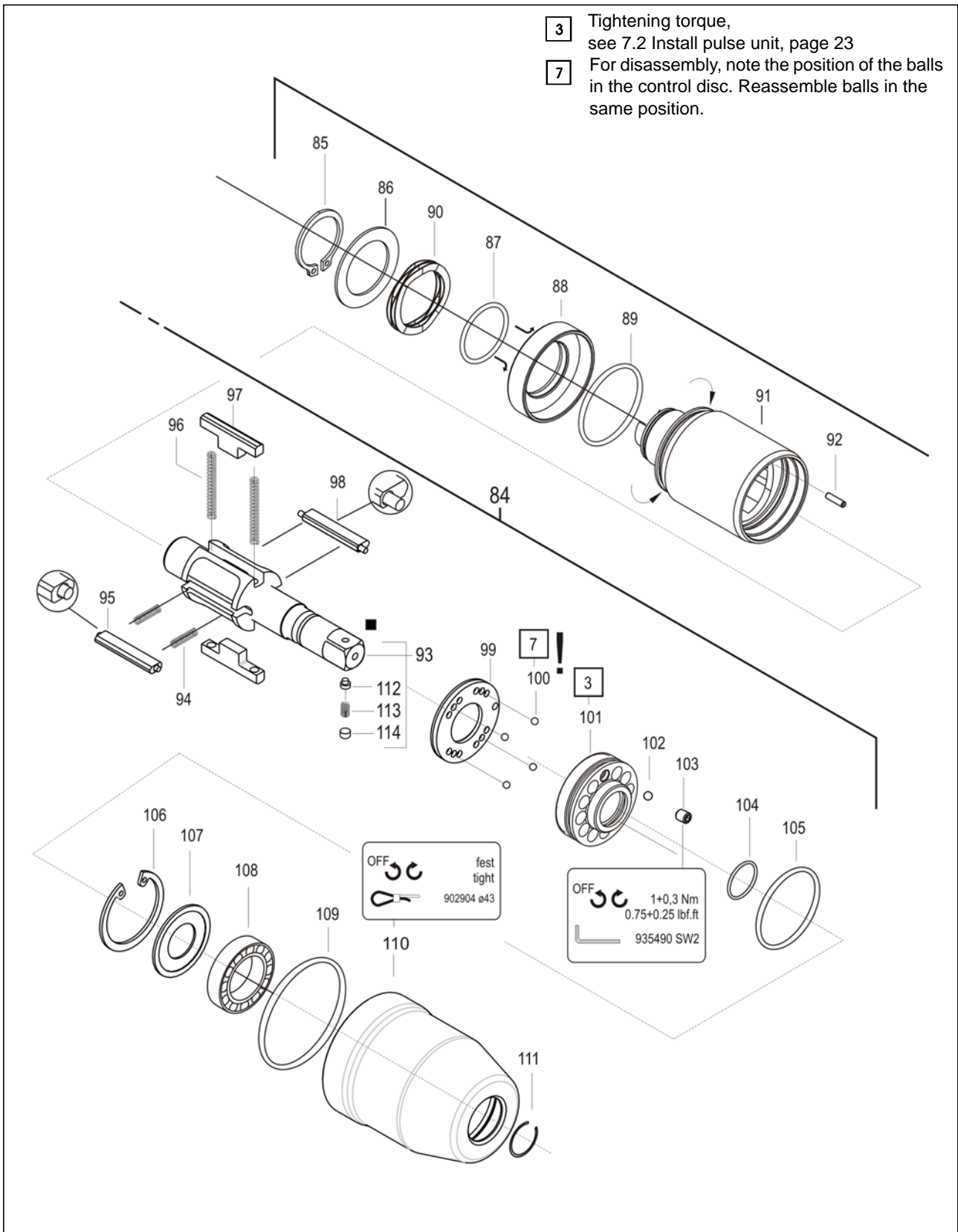



Index	1)	2)	3)	Description	4)
84	936045	1		pulse unit	
85	S918512	1	K2	circlip	21, X1,2 AR
86	933867	1	K2	shim ring	22, X 32, X 0,5
87	249380PT	1	K2	o-ring	21,95X1,78
88	936190	1		equalizing piston	
89	505719	1	K2	o-ring	29,87X1,78
90	936195	1	K2	equalizing washer	29, X 21, X 0,30
91	936186	1		hydraulic cylinder	
92	930587	1		needle roller	2,5 X9,8
93	935410	1		hydraulic rotor asm.	
94	932221	2	K2	compression spring	
95	935427	1		control blade asm.	
96	935461	2	K2	compression spring	0,40X 2,7 X 44,6
97	935426	2		hydraulic blade	
98	935429	1		control blade asm.	
99	935421	1		control disc	
100	917793	8	K2	ball	2,500MM
101	935417	1		bearing ring	
102	911315	1	K2	ball	3,000MM
103	919140	1	K2	set bolt	M4X5
104	929946	1	K2	o-ring	14,X2,
105	915076	1	K2	o-ring	30,X1,5
106	914147	1	K2	circlip	30,X1,2IR
107	935462	1		washer	
108	9D5834	1	K2	ball bearing	12,7 X 28,58X 6,35
109	935445	1	K1	o-ring	42,X1,5
110	937403PT	1		housing	
111	902180	1	K2	circlip	12,X1, AR
112	914517	1		pin	
113	9D6481	1		compression spring	0,3 X 3,2 X 9,2
114	281080	1		plug	

1)Order no.

2)Quantity

3) Part of hydraulic service kit K2, order no. 936211

4)Dimensions

## 8.5 Equipment order list

Index	1)	Description
A	928476	Oil filling device
	A1 928483	Oil filling unit
	A2 931968	Joining piece cpl.
B	936695PT	Reserve oil filling set
	B1 936690PT	Oil syringe asm.
	B2 937412PT	Spacer
C	938572PT	Assembly/Disassembly motor unit
	C1 933484	Support
	C2 933481	Semi-monocoque pair
	C3 933480	Punch
	C4 938573PT	Support 0,02 mm
	C5 938574PT	Support 0,03 mm
	C6 938575PT	Support 0,04 mm
	C7 938576PT	Support 0,05 mm
	C8 933487	Punch
	C9 938577PT	Support
D	933499	Assembly/Disassembly pulse unit
	D1 933494	Retainer
	D2 933496	Centering
	D3 933497	Socket wrench
E	933498	Installing the actuating ring
F	938535	Assembly hydraulic blade/control blade
	F1 938537	sleeve
	F2 938536	awl
G	933375	fixture for trigger valve

1)Order no.

## 9 Technical data

### 9.1 Dimensions 55PHH... in mm







Abb. 9-1

## 9.2 Dimensions 55PHHA... in mm

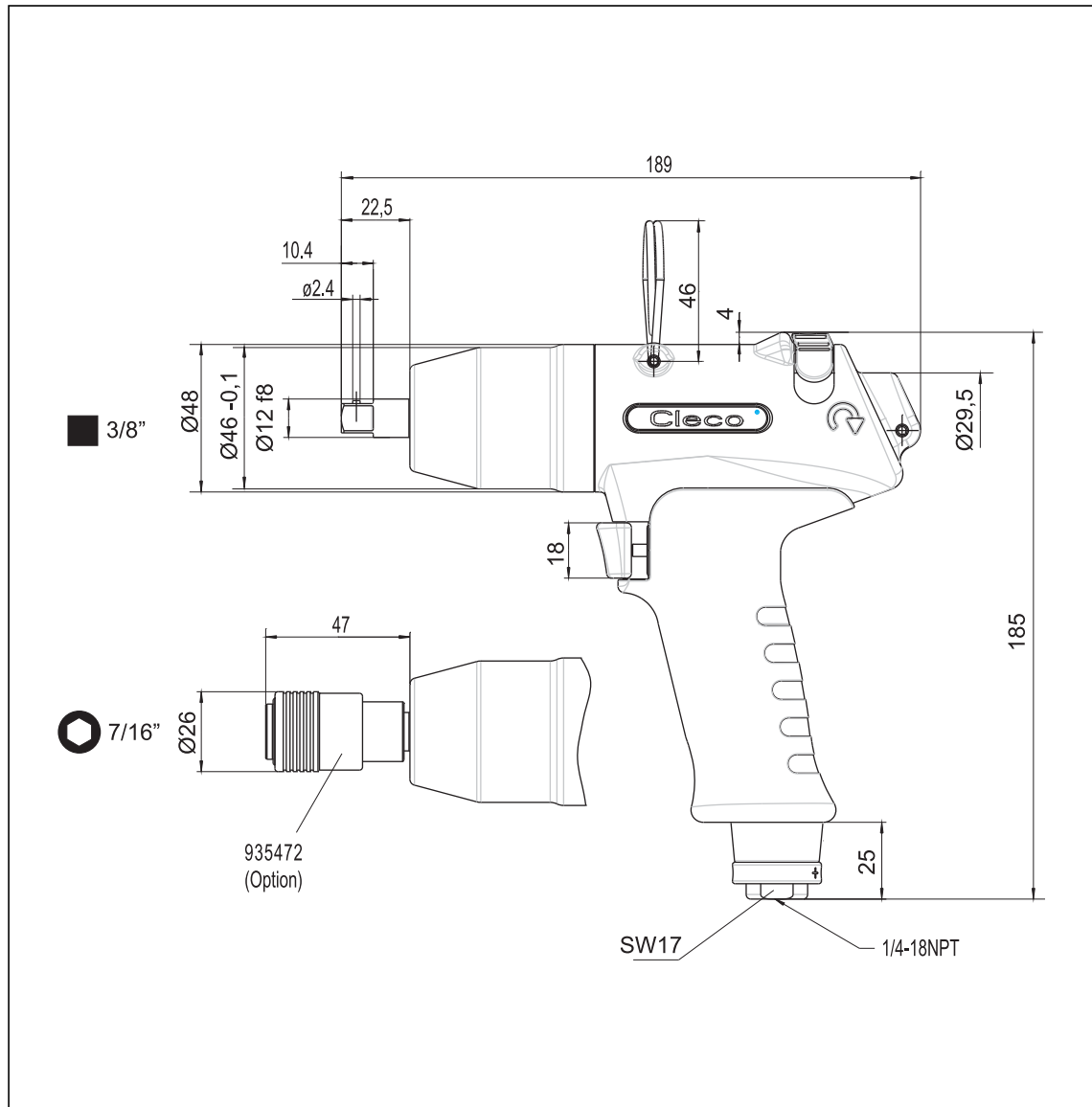
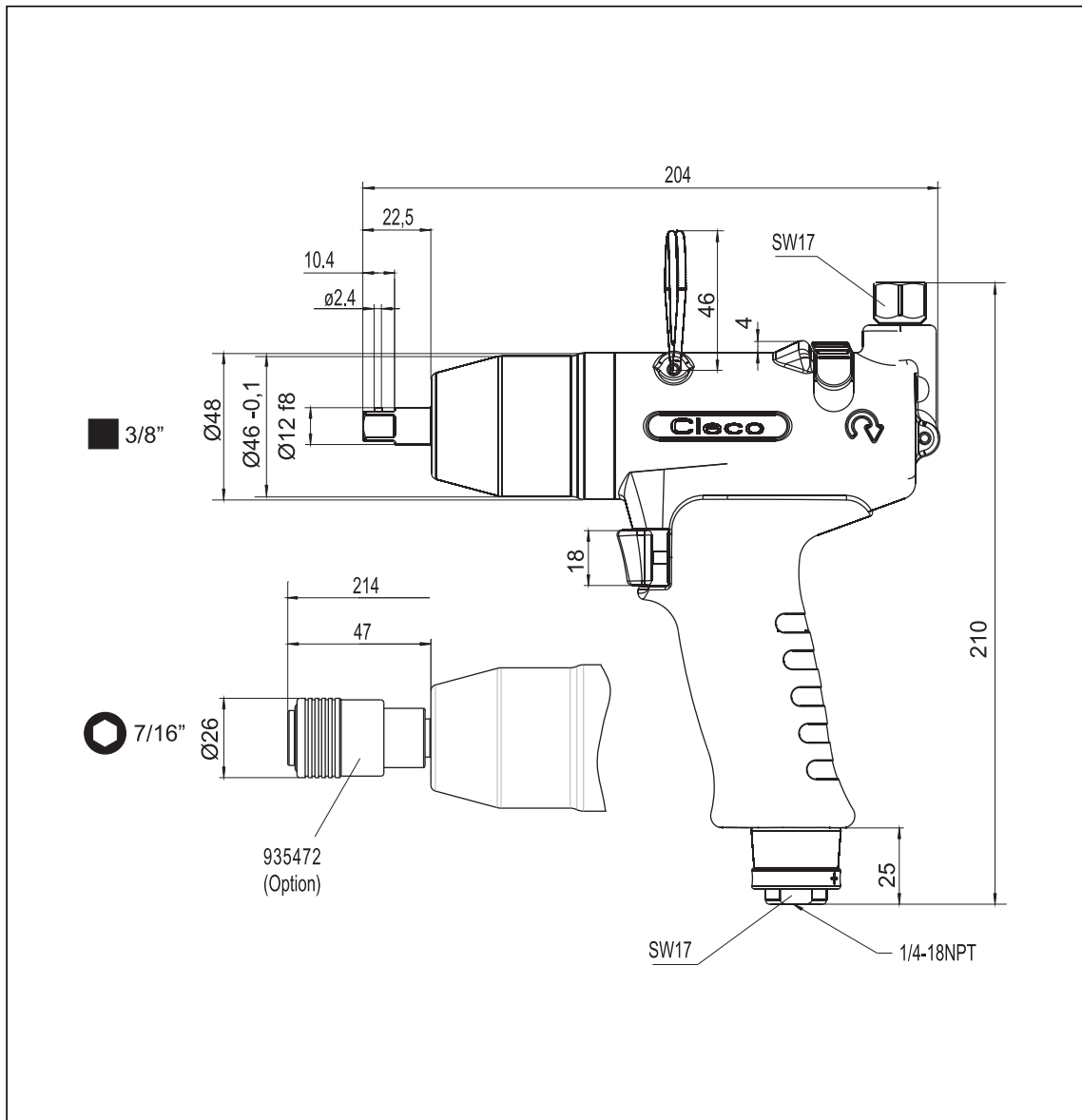

## 9.3 Performance Data

Order no.	Recommended torque range		Idling speed	 		Air consumption	
	Nm					m <sup>3</sup> /min	
	min.	max.	rpm	8.8 mm	kg	Idling	Pulses
55PHH603 55PHHA603	30	55	6000	M10	1.12	0.65	0.55
55PHH603 + 935472 55PHHA603 + 935472					1.17		
					1.18		
					1.23		

## 9.4 Ambient conditions

Storage temperature	-13° F (-25° C) ...+104° F (+60° C)
Working temperature	41° F (5° C) to a maximum of +104° F (+40° C)
Permissible relative humidity	25...90%, non-condensing

# 10 Service

### NOTE



In the event of repairs, send the complete 55PHH to Apex Tool Group. Repairs may only be carried out by authorized personnel. Opening the tool will invalidate the warranty.

# 11 Disposal

### CAUTION!



Injuries and environmental damage from improper disposal.  
The components and auxiliary materials of a machine incorporate risks to health and the environment.

- Catch auxiliary materials (oils, greases) when drained and dispose of them properly.
- Separate the machine parts by material and dispose of them properly.
- Separate the components of the packing and dispose of them by segregating them clearly.
- Wear suitable protective clothing at the time of disposal.
- Follow the general prevailing disposal guidelines.
- Follow the locally applicable regulations.

## POWER TOOLS SALES & SERVICE CENTERS

Please note that all locations may not service all products.  
Contact the nearest Apex Tool Group Sales & Service Center for the appropriate facility to handle your service requirements.

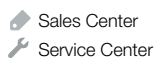

### NORTH AMERICA | SOUTH AMERICA

#### Detroit, Michigan

Apex Tool Group  
2630 Superior Court  
Auburn Hills, MI 48236  
Phone: +1 (248) 393-5640  
Fax: +1 (248) 391-6295

#### Lexington, South Carolina

Apex Tool Group  
670 Industrial Drive  
Lexington, SC 29072  
Phone: +1 (800) 845-5629  
Phone: +1 (919) 387-0099  
Fax: +1 (803) 358-7681

#### Louisville, Kentucky

Apex Tool Group  
1000 Glengarry Drive  
Suite 150  
Fairdale, KY 40118  
Phone: +1 (502) 708-3400  
apexpowertools.com/service

#### Canada

Apex Tool Canada, Ltd.  
7631 Bath Road  
Mississauga, Ontario L4T 3T1  
Canada  
Phone: (866) 691-6212  
Fax: (905) 673-4400

#### Mexico

Apex Tool Group  
Manufacturing México  
S. de R.L. de C.V.  
Vialidad El Pueblito #103  
Parque Industrial Querétaro  
Querétaro, QRO 76220  
Mexico  
Phone: +52 (442) 211 3800  
Fax: +52 (800) 685 5560

#### Brazil

Apex Tool Group  
Ind. Com. Ferram, Ltda.  
Av. Liberdade, 4055  
Zona Industrial Iporanga  
Sorocaba, São Paulo  
CEP# 18087-170  
Brazil  
Phone: +55 15 3238 3820  
Fax: +55 15 3238 3938

### EUROPE | MIDDLE EAST | AFRICA

#### England

Apex Tool Group GmbH  
C/O Spline Gauges  
Piccadilly, Tamworth  
Staffordshire B78 2ER  
United Kingdom  
Phone: +44 1827 8727 71  
Fax: +44 1827 8741 28

#### France

Apex Tool Group S.A.S.  
25 rue Maurice Chevalier  
B.P. 28  
77831 Ozoir-La-Ferrière  
Cedex, France  
Phone: +33 1 64 43 22 00  
Fax: +33 1 64 43 17 17

#### Germany

Apex Tool Group GmbH  
Industriestraße 1  
73463 Westhausen  
Germany  
Phone: +49 (0) 73 63 81 0  
Fax: +49 (0) 73 63 81 222

#### Hungary

Apex Tool Group  
Hungária Kft.  
Platánfa u. 2  
9027 Győr  
Hungary  
Phone: +36 96 66 1383  
Fax: +36 96 66 1135

### ASIA PACIFIC

#### Australia

Apex Tool Group  
519 Nurigong Street, Albury  
NSW 2640  
Australia  
Phone: +61 2 6058 0300

#### China

Apex Power Tool Trading  
(Shanghai) Co., Ltd  
2nd Floor, Area C  
177 Bi Bo Road  
Pu Dong New Area, Shanghai  
China 201203 P.R.C.  
Phone: +86 21 60880320  
Fax: +86 21 60880298

#### India

Apex Power Tools India  
Private Limited  
Gala No. 1, Plot No. 5  
S. No. 234, 235 & 245  
Indialand Global  
Industrial Park  
Taluka-Mulsi, Phase I  
Hinjawadi, Pune 411057  
Maharashtra, India  
Phone: +91 020 66761111

#### Japan

Apex Tool Group Japan  
Korin-Kaikan 5F,  
3-6-23 Shibakoen, Minato-Ku,  
Tokyo 105-0011, JAPAN  
Phone: +81-3-6450-1840  
Fax: +81-3-6450-1841

#### Korea

Apex Tool Group Korea  
#1503, Hibrand Living Bldg.,  
215 Yangjae-dong,  
Seocho-gu, Seoul 137-924,  
Korea  
Phone: +82-2-2155-0250  
Fax: +82-2-2155-0252

#### Apex Tool Group, LLC

1000 Lufkin Road  
Apex, NC 27539  
Phone: +1 (919) 387-0099  
Fax: +1 (919) 387-2614  
www.apexpowertools.com

