

Parts Manual
PL12-1006EN
11/26/2012

Cleco®

48EP Series
High Torque Swing Bar Nutrunners



For additional product information visit our website at <http://www.apextoolgroup.com>

“A”

48	E	P	X	XXX	XX
-----------	----------	----------	----------	------------	-----------

Tool Series

48

Motor Style

E = Brushless Electric Motor

Tool Type

P = Pistol Grip

Feature 1

- = Matrix Tool Connector (Standard)

E = Air LB Connector

Maximum Torque NM (Rounded to nearest Nm)

200 = 200 Nm (D6)

325 = 325 Nm (D6)

500 = 500 Nm (D6)

1000 = 1000 Nm (D8)

Attachment

D6 = 3/4" Square Drive

D8 = 1" Square Drive

“B”

m-Pro-400 Series
Controller



TME-200 Series
Controller



Tool In/Out

Tool Cable



Complete Tool
Order No.
48EP(E)200D6
48EP(E)325D6
48EP(E)500D6
48EP(E)1000D8

m-Pro-400GC
Global Controller



Tool Cable



m-Pro-400-IT
Isolation Transformer
(48EP Models)

Tool Cable



48EPE Models

48EP	48EPE	EN
		Description
TME-200	m-Pro-400	Controller
PL12()-1300	*	Programming Notes
575708	*	Battery
541683-01	*	Power Cord - 115VAC - USA
541683-02	*	Power Cord - 230VAC - USA
541683-03	*	Power Cord - 230VAC - Europe
542779-XXX	960430-XXX	Extension Cable
544056-XXX	961251-XXX	Swivel Cable
544055-XXX	961252-XXX	Swivel Cable (90°)
542778-XXX	961250-XXX	Tool Cable

* Note: Contact your Apex Tool Group representative

TME-200 Series Controller

Supply Voltage	EN
	Order Number
115 VAC	TME-211-15-U
115 VAC	TME-221-15-U
230 VAC	TME-211-30-U
230 VAC	TME-211-30-U

“C”

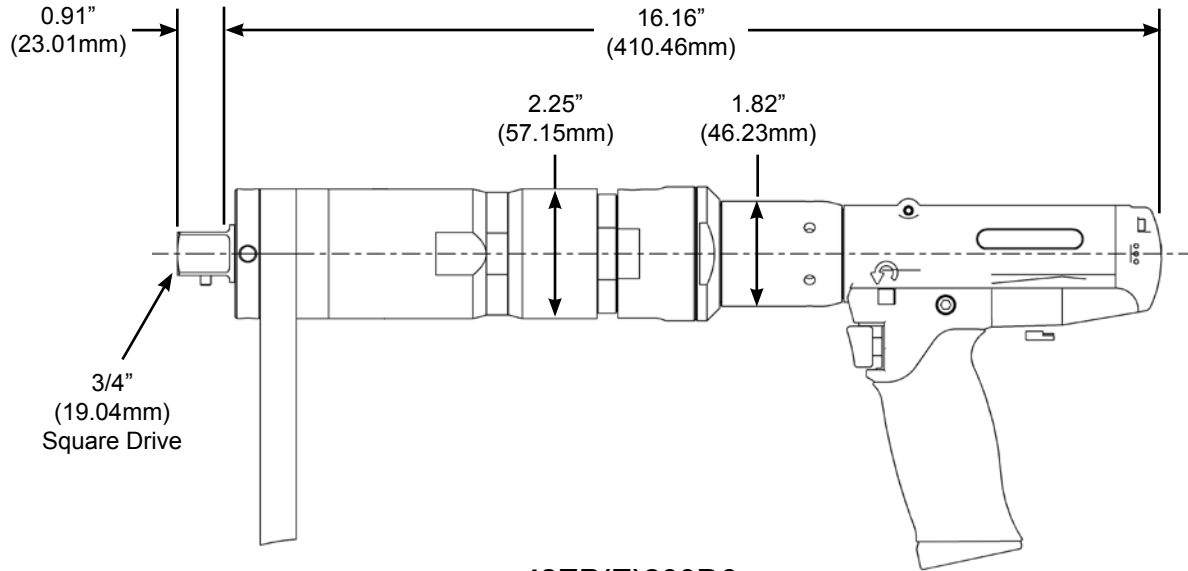

**48EP(E)200D6
48EP(E)325D6
48EP(E)500D6**

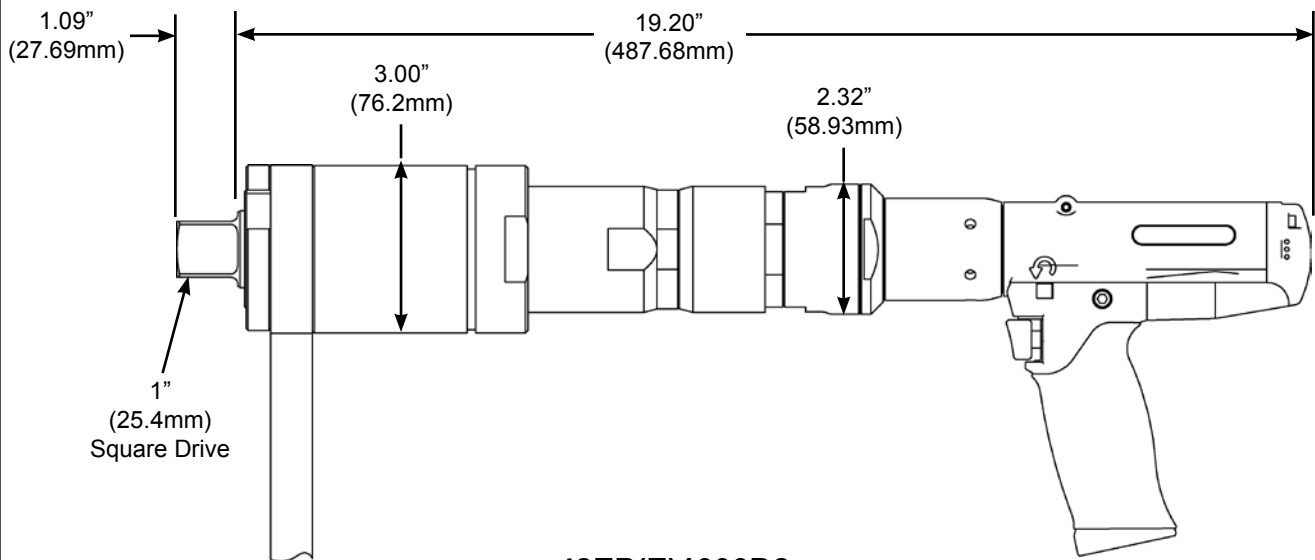

48EP(E)1000D8

“D”

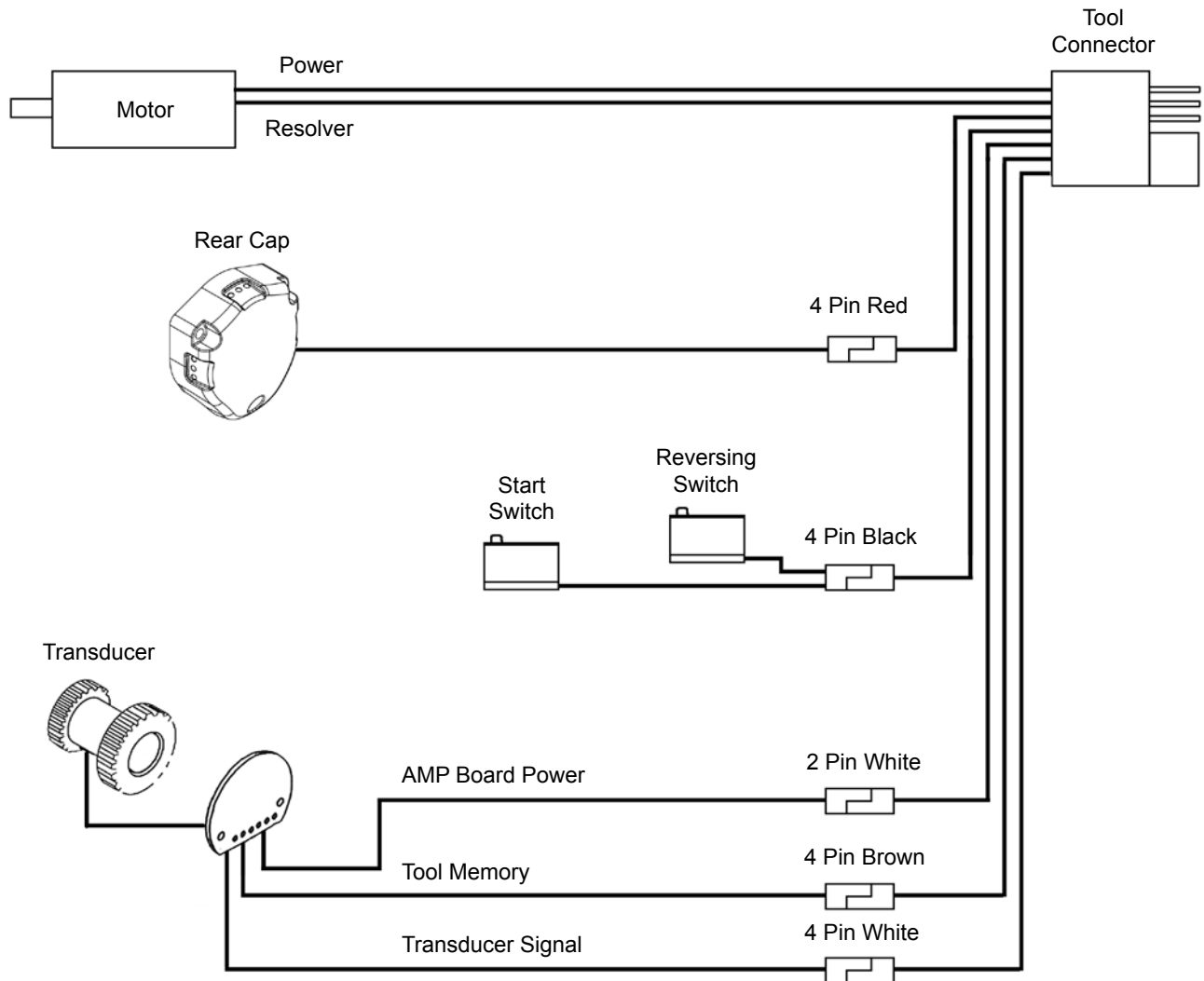

“E1” Reference: Assembly Sequence

Models
48EP200D6
48EP325D6
48EP500D6
48EP1000D8

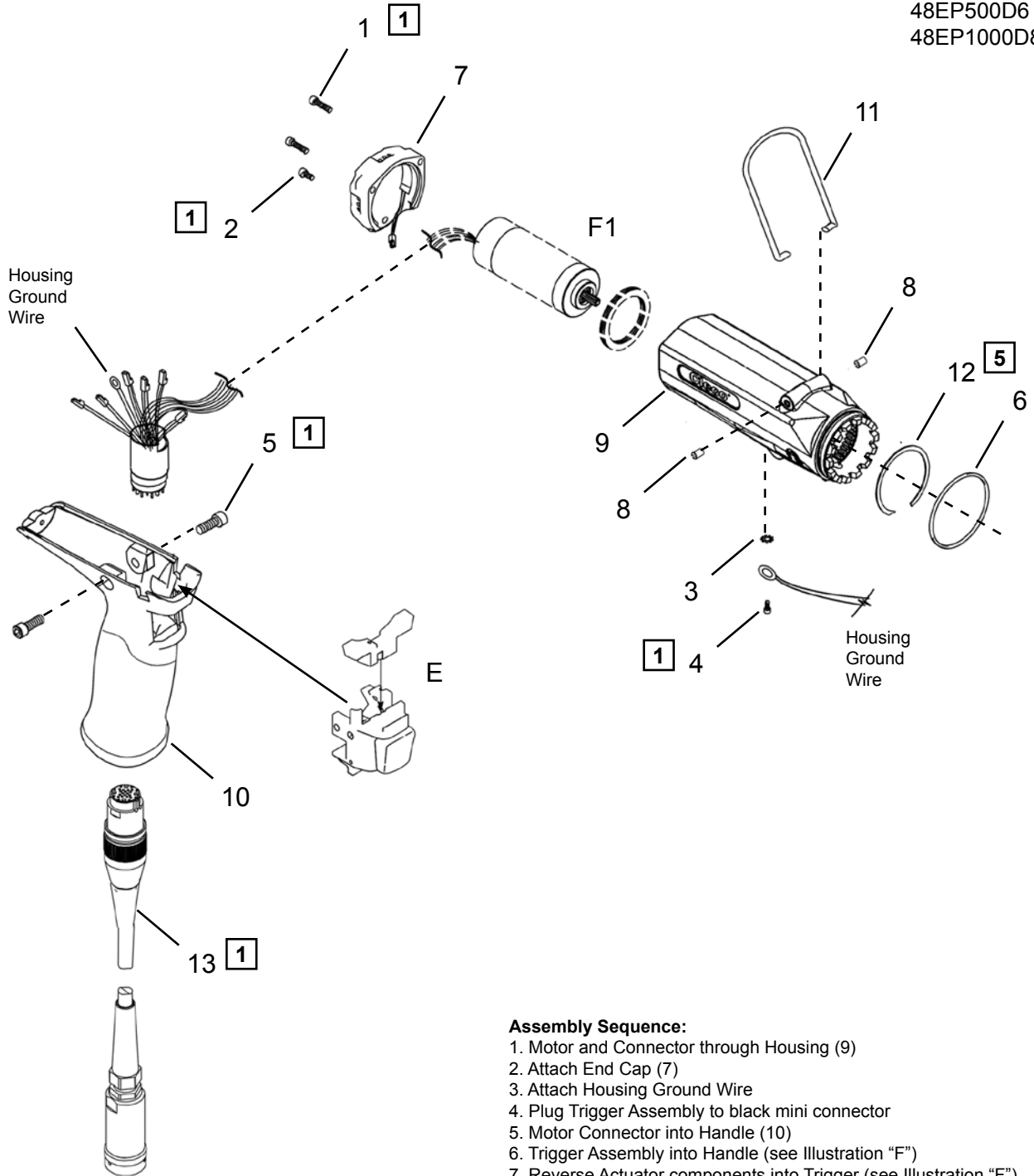

Assembly Sequence:

1. Motor and Connector through Housing (9)
2. Attach End Cap (7)
3. Attach Housing Ground Wire
4. Plug Trigger Assembly to black mini connector
5. Motor Connector into Handle (10)
6. Trigger Assembly into Handle (see Illustration "F")
7. Reverse Actuator components into Trigger (see Illustration "F")

1 5 See Service Notes

Handle - Matrix Tool Connector

Illustration "E1"

Ref	Number	#	X	EN
				Description
1	B121A	2	4	Cap Screw
2	B124R	1	3	Cap Screw
3	W115	1	4	Lockwasher
4	541927	1	3	Screw
5	B122S	2	4	Cap Screw
6	22598	1	3	O-Ring
7	542820	1		Rear Cap
8	931791	2	4	Spring Pin
9	542679	1		Top Handle
10	207338	1		Bottom Handle
11	931962	1	1	Suspension Bail
12	505306	1	1	Retaining Ring
Tool Cable (Optional Length)				
13	542778-1M	1		1 meter cable
	542778-2M			2 meter cable
	542778-3M			3 meter cable
	542778-6M			6 meter cable
	542778-8M			8 meter cable
	542778-10M			10 meter cable
	542778-15M			15 meter cable
	542778-50M			50 meter cable
Inline Swivel Cable (Optional Length)				
13	544056-1M	1		1 meter cable
	544056-2M			2 meter cable
	544056-3M			3 meter cable
	544056-6M			6 meter cable
	544056-8M			8 meter cable
	544056-10M			10 meter cable
	544056-15M			15 meter cable
Angle Swivel Cable (Optional Length)				
13	544055-1M	1		1 meter cable
	544055-2M			2 meter cable
	544055-3M			3 meter cable
	544055-6M			6 meter cable
	544055-8M			8 meter cable
	544055-10M			10 meter cable
	544055-15M			15 meter cable
Tool Cable Extension (Optional Length)				
13	542779-1M	1		1 meter cable
	542779-2M			2 meter cable
	542779-3M			3 meter cable
	542779-6M			6 meter cable
	542779-10M			10 meter cable
	542779-15M			15 meter cable
	542779-50M			50 meter cable

(#) Quantity

(X) Recommended Spare Parts

“E2” Reference: Assembly Sequence

Models

- 48EPE200D6
- 48EPE325D6
- 48EPE500D6
- 48EPE1000D8

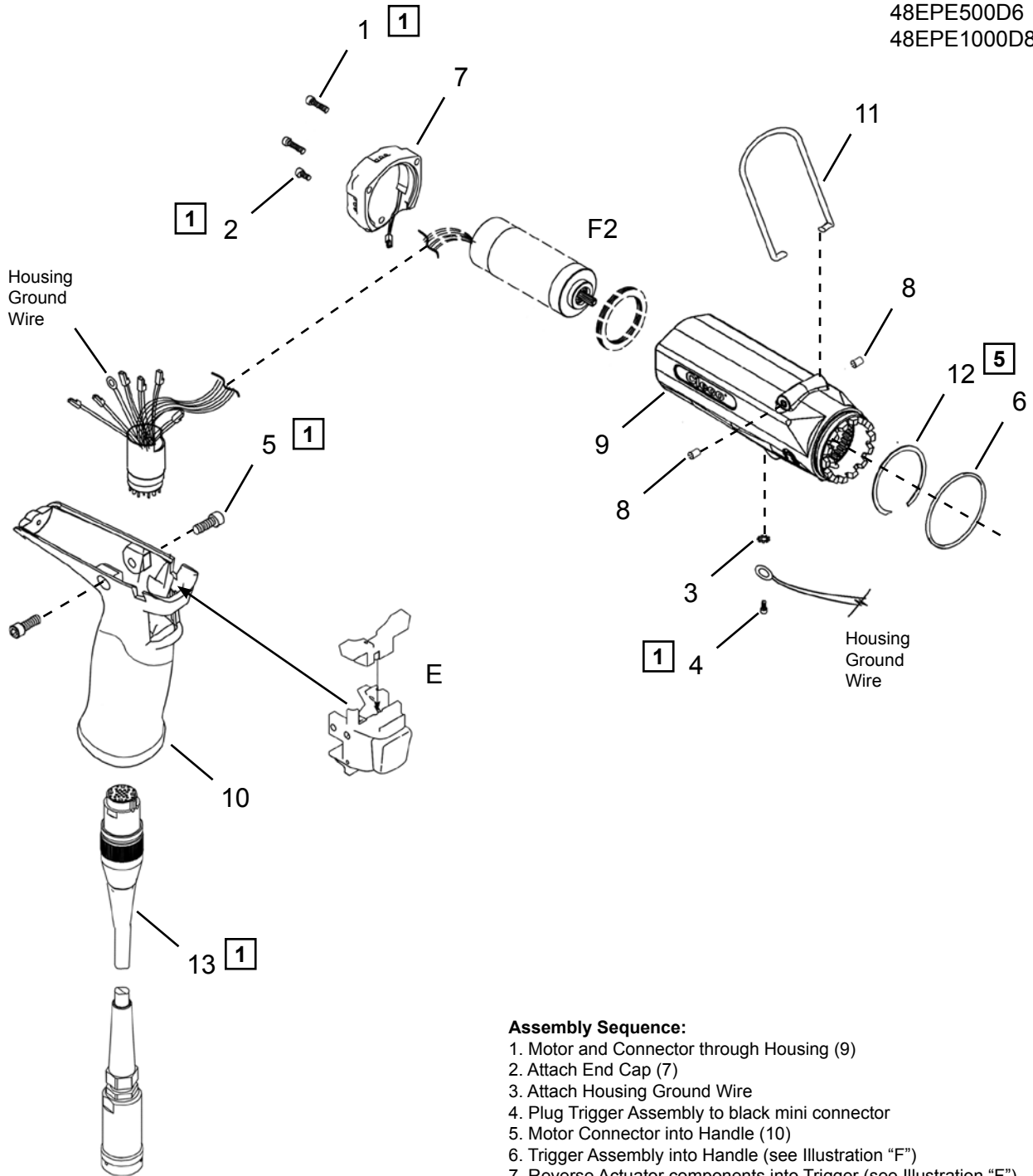

Assembly Sequence:

1. Motor and Connector through Housing (9)
2. Attach End Cap (7)
3. Attach Housing Ground Wire
4. Plug Trigger Assembly to black mini connector
5. Motor Connector into Handle (10)
6. Trigger Assembly into Handle (see Illustration “F”)
7. Reverse Actuator components into Trigger (see Illustration “F”)

1 5 See Service Notes

Handle - Air LB Connector

Illustration "E2"

Ref	Number	#	X	EN	
				Description	
1	B121A	2	4	Cap Screw	
2	B124R	1	3	Cap Screw	
3	W115	1	4	Lockwasher	
4	541927	1	3	Screw	
5	B122S	2	4	Cap Screw	
6	22598	1	3	O-Ring	
7	542820	1		Rear Cap	
8	931791	2	4	Spring Pin	
9	542679	1		Top Handle	
10	207338E	1		Bottom Handle	
11	931962	1	1	Suspension Bail	
12	505306	1	1	Retaining Ring	
Tool Cable (Optional Length) - Additional lengths available on request					
13	301866-2M	1		2 meter cable	
	301866-3M			3 meter cable	
	301866-4M			4 meter cable	
	301866-6M			6 meter cable	
	301866-8M			8 meter cable	
	301866-10M			10 meter cable	
	301866-15M			15 meter cable	
Inline Swivel Cable (Optional Length) - Additional lengths available on request					
13	301904-2M	1		2 meter cable	
	301904-3M			3 meter cable	
	301904-8M			8 meter cable	
	301904-15M			15 meter cable	
Angle Swivel Cable (Optional Length) - Additional lengths available on request					
13	301903-2M	1		2 meter cable	
	301903-3M			3 meter cable	
	301903-8M			8 meter cable	
	301903-15M			15 meter cable	
Tool Cable Extension (Optional Length) - Additional lengths available on request					
13	301877-4M	1		4 meter cable	
	301877-8M			8 meter cable	
	301877-10M			10 meter cable	
	301877-20M			20 meter cable	
	301877-30M			30 meter cable	
	301877-40M			40 meter cable	
	301877-50M			50 meter cable	

(#) Quantity

(X) Recommended Spare Parts

Cleco® Trigger Assembly

"F"

Reference: Assembly Sequence

Models

48EP(E)200D6
48EP(E)325D6
48EP(E)500D6
48EP(E)1000D8

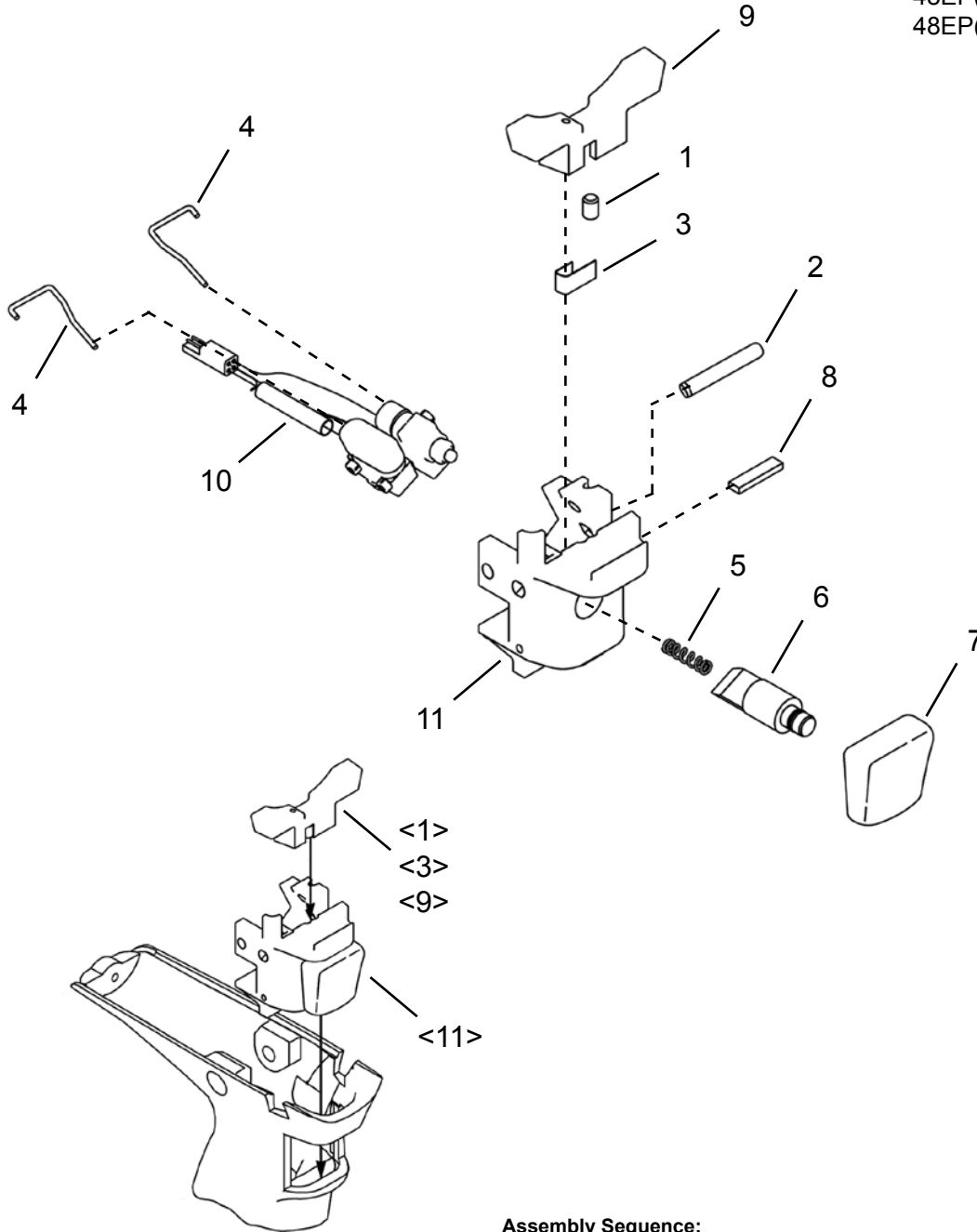

Not to Scale

Assembly Sequence:

Squeeze trigger slightly and slide downward into position.
Install the Reverse Actuator and components (1,3,9) into trigger.

Cleco®
Trigger Assembly

PL12-1006EN
11/26/2012

Illustration "F"

Ref	Number	#	X	EN
				Description
1	1007441	1	3	Detent Pin
2	843280	1	2	Pin
3	207318	1		Leaf Spring
4	935077	2	3	Spring Pin
5	913365	1	3	Spring
6	207315	1		Trigger Shaft
7	1110038	1		Trigger
8	542088	1	3	Foam Pad
9	207314	1		Reverse Actuator
10	301729	1	2	Start / Reverse Switch
11	207313	1		Switch Housing

(#) Quantity

(X) Recommended Spare Parts

Cleco® Motor - Matrix Tool Connector

“G1”

Models

- 48EP200D6
- 48EP325D6
- 48EP500D6
- 48EP1000D8

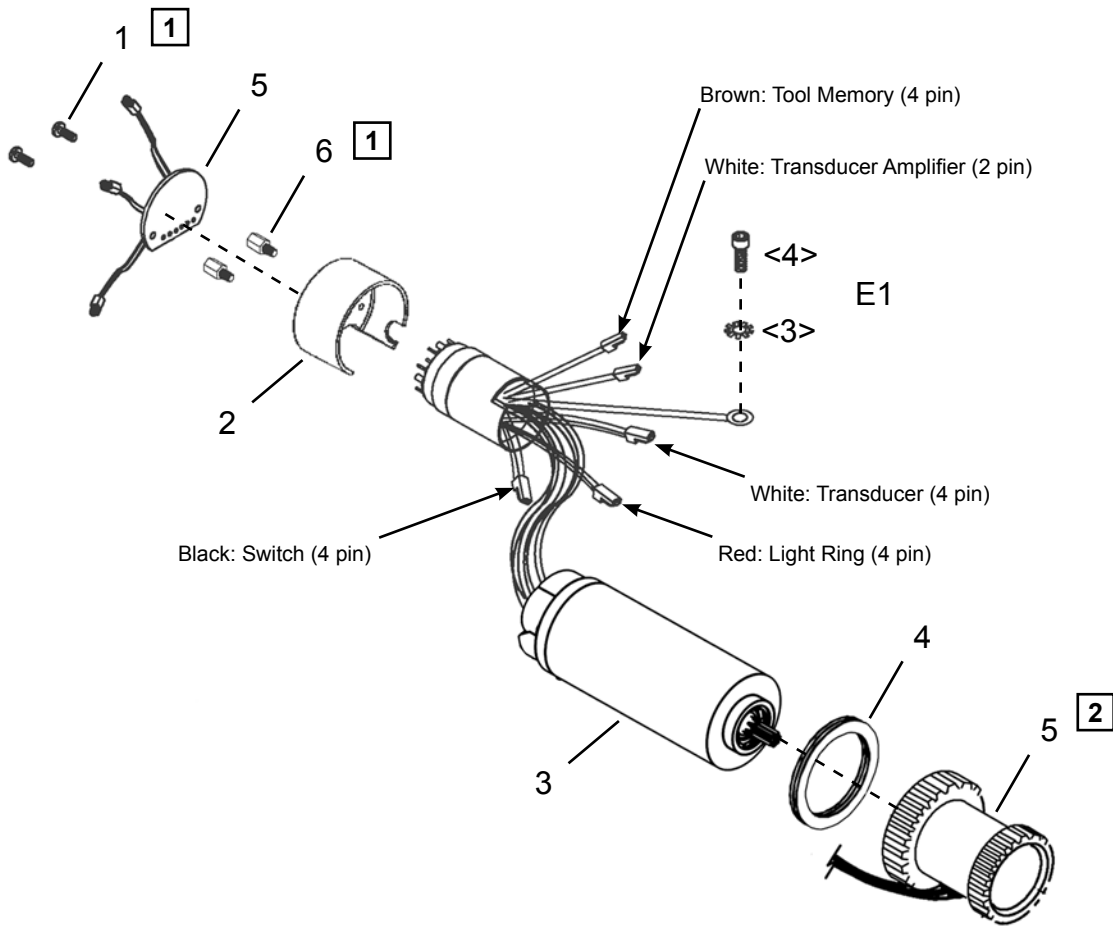

[1] [2] See Service Notes

Cleco®
Motor - Matrix Tool Connector

PL12-1006EN
11/26/2012

Illustration "G1"

Ref	Number	#	X	EN
				Description
1	17-111	2	4	Pan Head Screw
2	542588	1		Motor Spacer
3	301761	1		Motor Assembly
4	542098	1	2	Wave Spring
5	Table "G1"	1		Transducer Assembly
6	542244	2	2	Stand Off

(#) Quantity

(X) Recommended Spare Parts

Table "G1"

Ref.	Description	#	48EP200 48EP325 48EP500 48EP1000
5	Transducer (unprogrammed)	1	542846-12
	Transducer (programmed)	1	542846-12P
	Capacity		12 Nm

Cleco®
Motor - Air LB Connector

“G2”

Models
48EPE200D6
48EPE325D6
48EPE500D6
48EPE1000D8

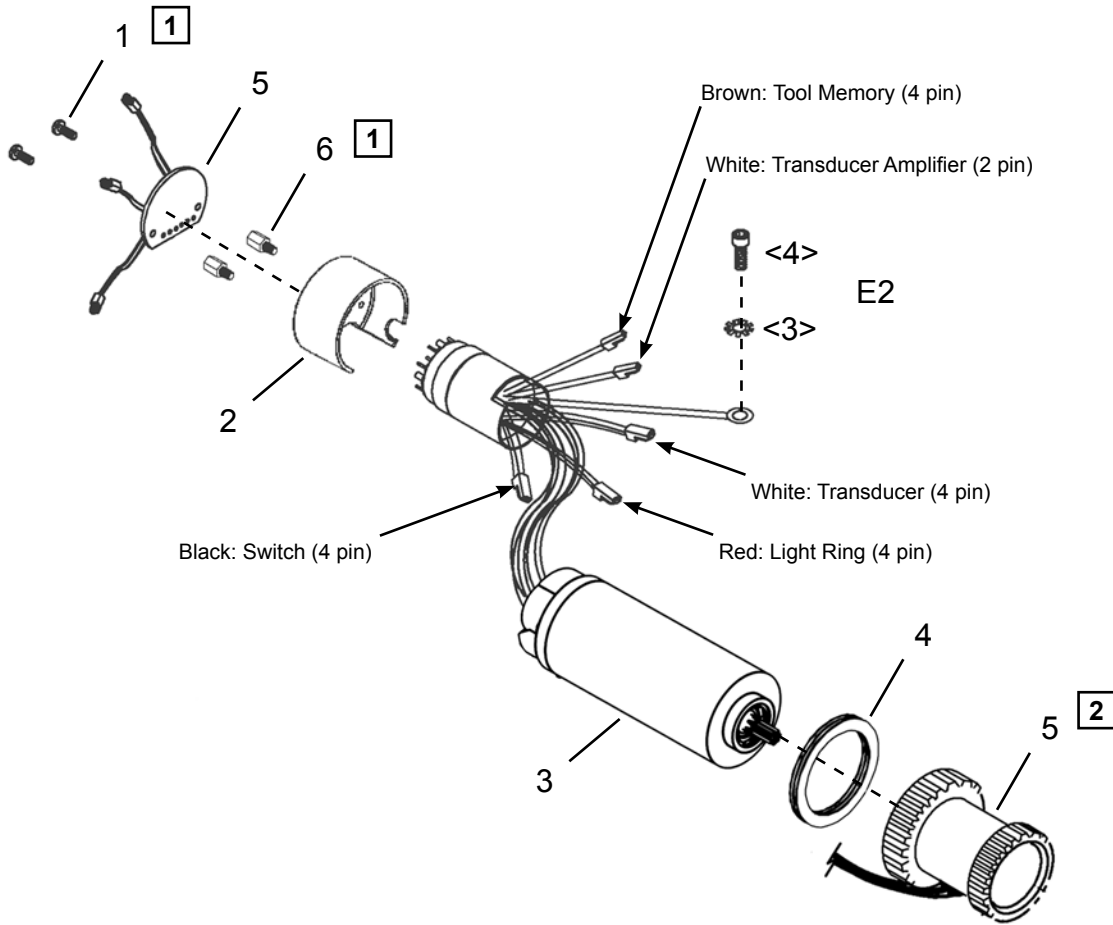

1 **2** See Service Notes

Cleco®
Motor - Air LB Connector

PL12-1006EN
11/26/2012

Illustration "G2"

Ref	Number	#	X	EN
				Description
1	17-111	2	4	Pan Head Screw
2	542588	1		Motor Spacer
3	301761E	1		Motor Assembly
4	542098	1	2	Wave Spring
5	Table "G2"	1		Transducer Assembly
6	542244	2	2	Stand Off

(#) Quantity

(X) Recommended Spare Parts

Table "G2"

Ref.	Description	#	48EPE200 48EPE325 48EPE500 48EPE1000
5	Transducer (unprogrammed)	1	542846-12
	Transducer (programmed)	1	542846-12P
	Capacity		12 Nm

Cleco®
Gearing - Upper Stage

“H”

Models
48EP(E)200D6
48EP(E)325D6
48EP(E)500D6
48EP(E)1000D8

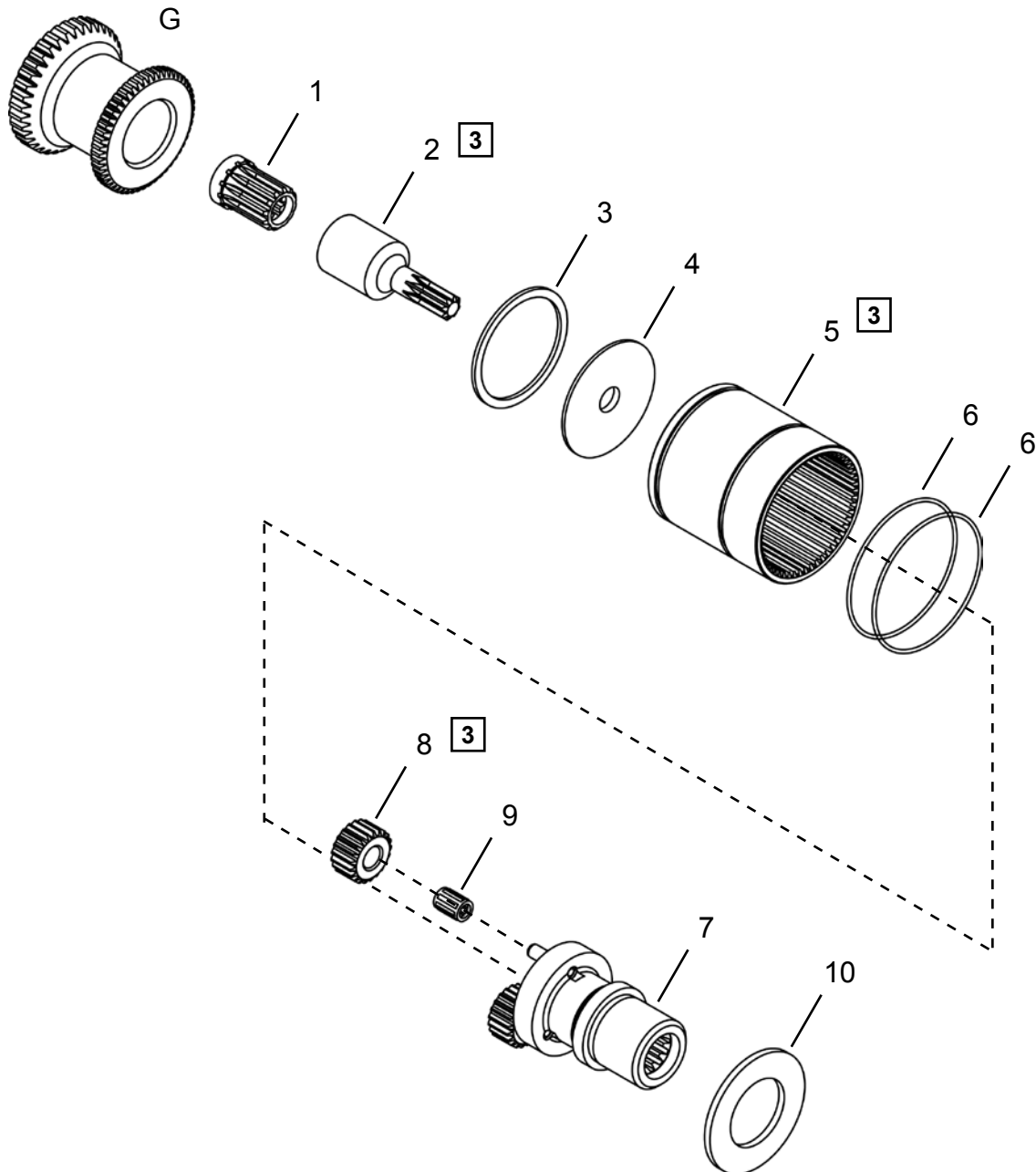

3 See Service Notes

Cleco®
Gearing - Upper Stage

PL12-1006EN
11/26/2012

Illustration "H"

Ref	Number	#	X	EN
				Description
1	541044	1	2	Pinion Adapter
2	541898	1	2	Extension Pinion
3	800116	1	2	Retaining Ring
4	541887	1	2	Washer
5	542722	1		Ring Gear
6	542724	2	6	O-Ring
7	207504	1		Planet Carrier
8	541893	3	6	Planet Gear (21T)
9	541487	3	6	Needle Bearing
10	502983	1	2	Thrust Washer

(#) Quantity

(X) Recommended Spare Parts

(T) Teeth

Cleco® Swivel Assembly

“1”

Models
48EP(E)200D6
48EP(E)325D6
48EP(E)500D6
48EP(E)1000D8

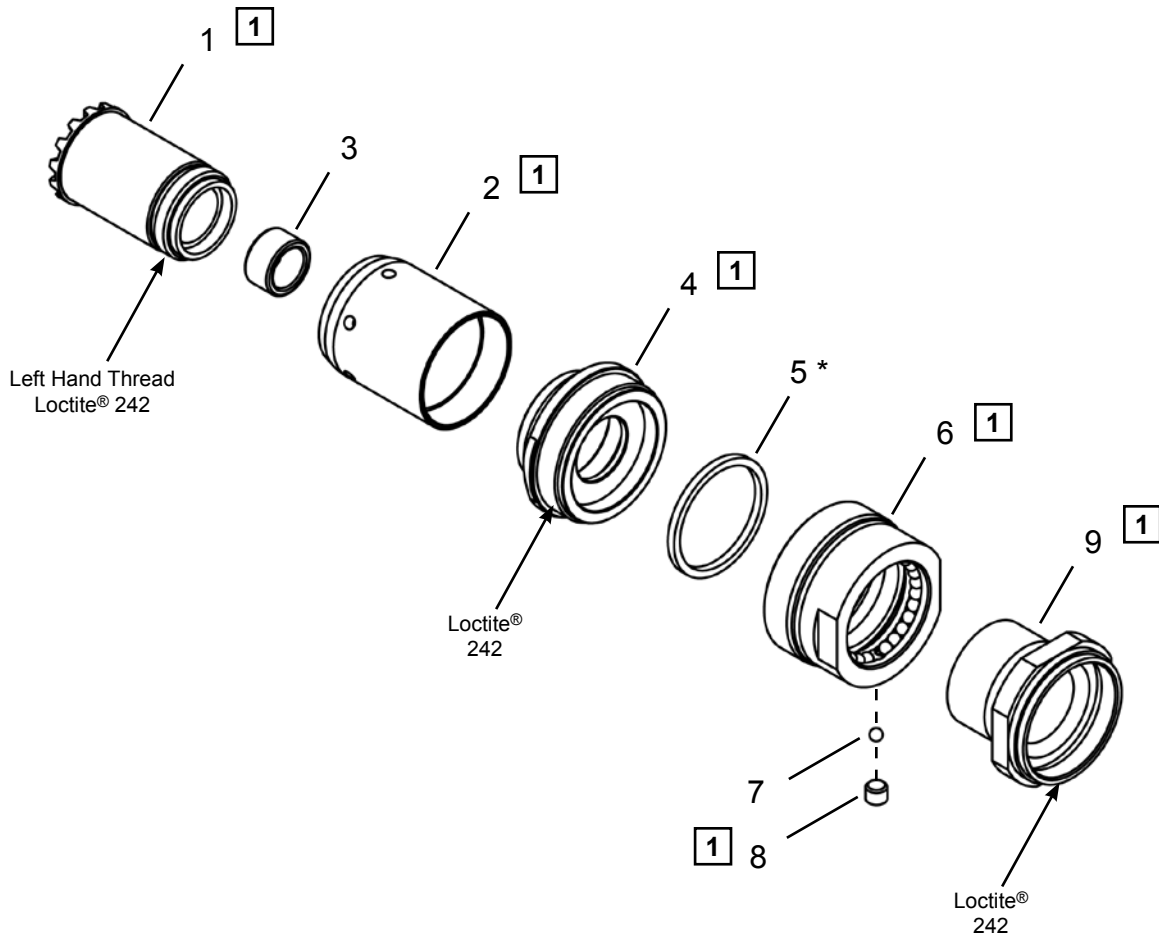

1 See Service Notes

Cleco®
Swivel Assembly

PL12-1006EN
11/26/2012

Illustration "I"

Ref	Number	#	X	EN
				Description
1	207347	1		Adapter
2	543462-02	1		Gear Case Nut
3	500528	1	2	Bearing
4	207554PT	1		Swivel Adapter
5	93050015	1	3	Packing Seal
6	542956	1		Swivel Motor Housing
7	94010008	27	54	Steel Ball (3/16")
8	12601432	1	2	Pipe Plug
9	48177102	1		Swivel Gear Housing

(#) Quantity

(X) Recommended Spare Parts

Models
48EP(E)200D6
48EP(E)325D6

“J”

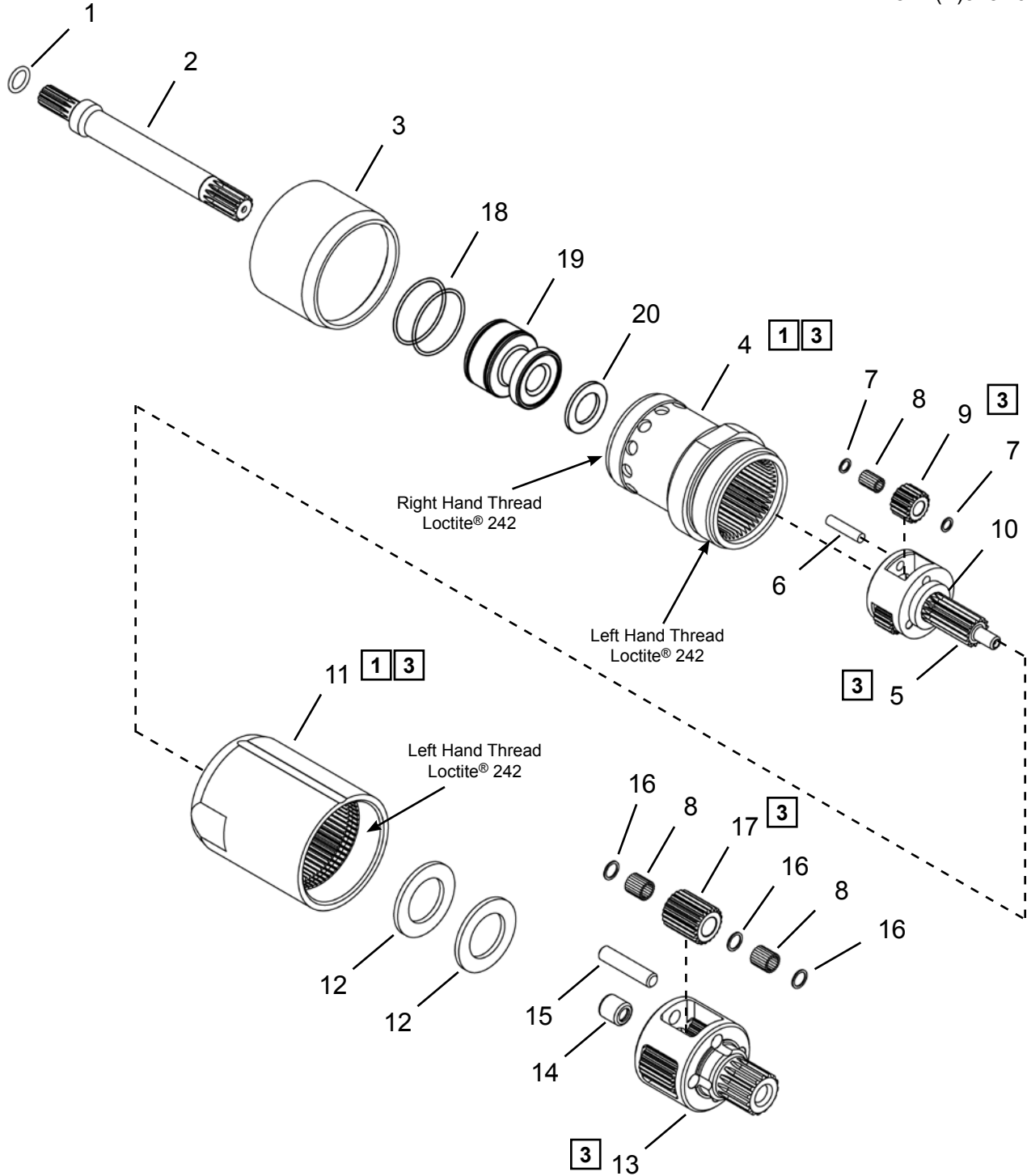

1 3 See Service Notes

Cleco®
Gearing - Central

PL12-1006EN
11/26/2012

Illustration "J"

Ref	Number	#	X	EN
				Description
1	1008680	1	3	O-Ring
2	Table "J"	1		Pinion Shaft
3	207555PT	1		Cover
4	48037107	1		Gear Housing
5	Table "J"	1		Planet Carrier (includes Ref. 10)
6	48019110	3	6	Planet Gear Pin
7	48019118	6	12	Planet Gear Washer
8	92880015	213	426	Needle Roller
9	Table "J"	3	6	Planet Gear
10	48039157	1	1	Spacer
11	46037183	1		Gear Housing
12	92060018	2	2	Thrust Race
13	46036184	1		Planet Carrier
14	92000008	1	2	Needle Bearing
15	46039190	4	8	Planet Gear Pin
16	460391100	12	24	Planet Gear Washer
17	46038191	4	8	Planet Gear (21T)
18	60888	2	6	O-Ring
19	Table "J"	1		Spacer
20	884083	1	2	Thrust Washer

(#) Quantity
(X) Recommended Spare Parts
(T) Teeth

Table "J"

Ref.	Description	#	48EP(E)200D6	#	48EP(E)324D6
2	Pinion Shaft	1	207562PT	1	207560PT
5	Planet Carrier	1	46037187	1	207561PT
9	Planet Gear	3	48048111 (17T)	3	48048110 (20T)
19	Spacer	1	207557PT	1	207558PT

(T) Teeth

“K”

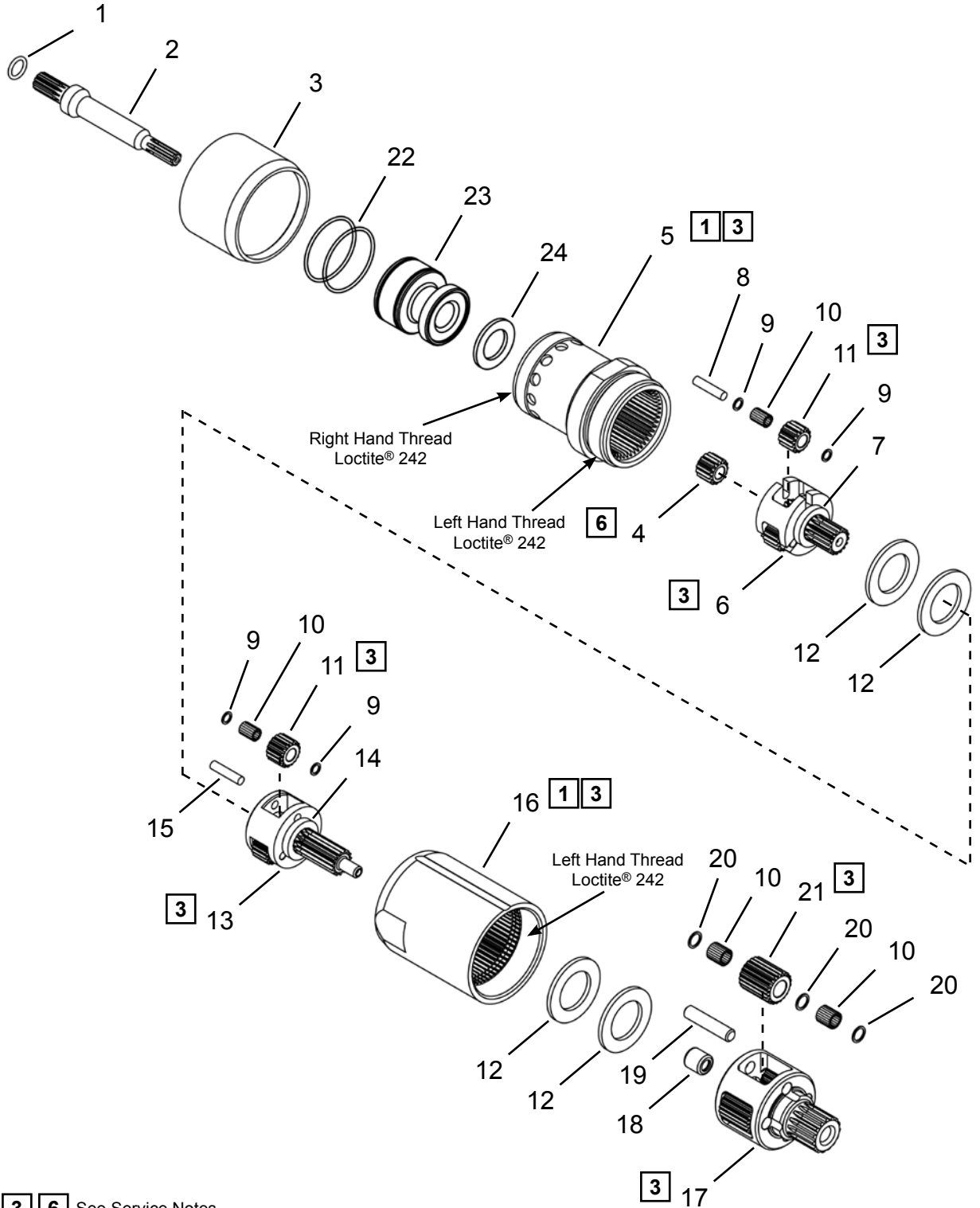

1 **3** **6** See Service Notes

Cleco®
Gearing - Central

PL12-1006EN
11/26/2012

Illustration "K"

Ref	Number	#	X	EN
				Description
1	1008680	1	3	O-Ring
2	207559PT	1		Pinion Shaft
3	207555	1		Cover
4	48038118	1	2	Splined Pinion Gear
5	48037107	1		Gear Housing
6	48037125	1		Planet Carrier (includes Ref. 7)
7	48039178	1	1	Spacer
8	48019110	3	6	Planet Gear Pin
9	48019118	12	24	Planet Gear Washer
10	92880015	258	258	Needle Roller
11	48038129	6	12	Planet Gear (15T)
12	92060018	4	4	Thrust Race
13	46037200	1		Planet Carrier (includes Ref. 14)
14	48039157	1	1	Spacer
15	48019110	3	6	Planet Gear Pin
16	46037183	1		Gear Housing
17	46036184	1		Planet Carrier
18	92000008	1	2	Needle Bearing
19	46039190	4	8	Planet Gear Pin
20	460391100	12	24	Planet Gear Washer
21	46038191	4	8	Planet Gear (21T)
22	60888	2	6	O-Ring
23	207557PT	1		Spacer
24	884083	1	2	Thrust Washer

(#) Quantity
(X) Recommended Spare Parts
(T) Teeth

“L”

Models
48EP(E)200D6
48EP(E)325D6
48EP(E)500D6

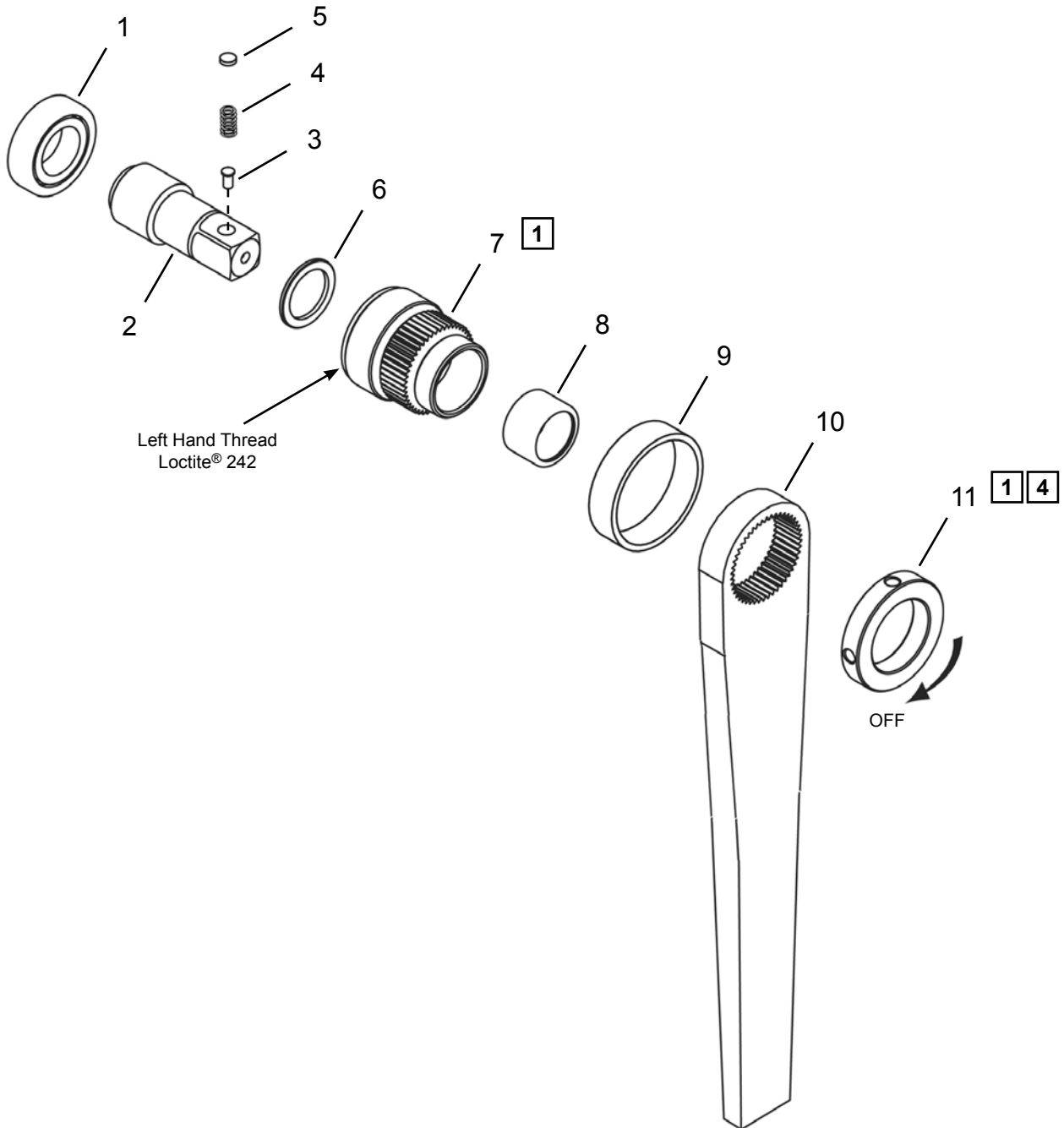

1 4 See Service Notes

Cleco®
Gearing - Output

PL12-1006EN
11/26/2012

Illustration "L"

Ref	Number	#	X	EN
				Description
1	92100031	1	2	Ball Bearing
2	46037195	1		Output Spindle (3/4" Square Drive) (includes Ref. 3-4-5)
3	12031048	1	3	Socket Locking Pin
4	94070240	1	3	Spring
5	12601479A	1	3	Plug
6	48039132	1	1	Spacer
7	48037109	1		Bearing Cap
8	92000056	1	2	Needle Bearing
9	48038126	1		Spacer
10	48037148	1		Torque Bar
11	48038113	1		Lock Nut

(#) Quantity

(X) Recommended Spare Parts

Cleco®
Gearing - Lower Stage

Models
48EP(E)1000D8

“M”

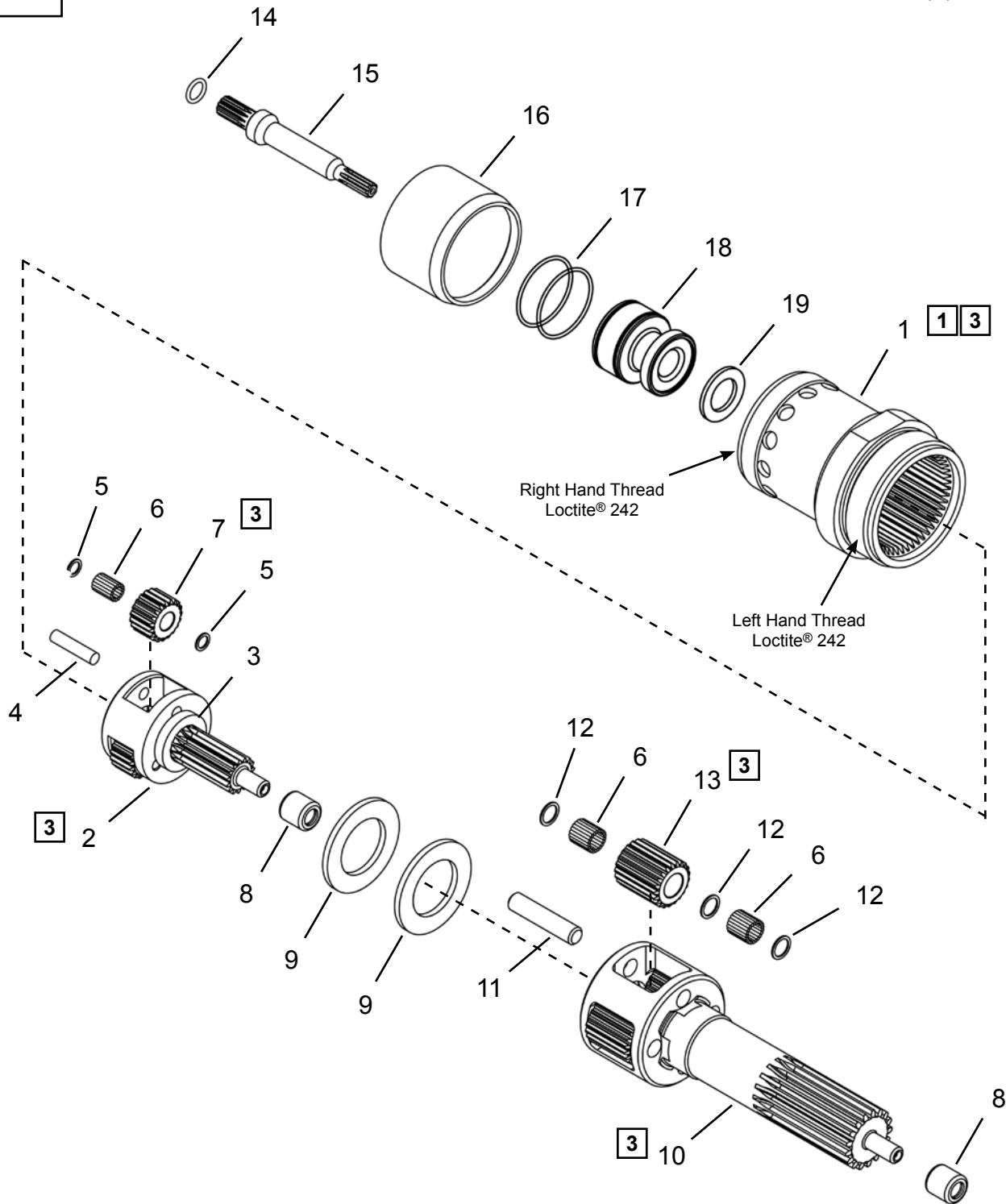

1 3 See Service Notes

Cleco®
Gearing - Lower Stage

PL12-1006EN
11/26/2012

Illustration "M"

Ref	Number	#	X	EN
				Description
1	48037107	1		Gear Housing
2	207565PT	1		Planet Carrier (includes Ref. 3)
3	48039178	1	1	Spacer
4	48019110	3	6	Planet Gear Pin
5	48019118	3	6	Planet Gear Washer
6	92880015	213	213	Needle Roller
7	48018117	3	6	Planet Gear (19T)
8	92000008	2	4	Needle Bearing
9	92060018	2	2	Thrust Race
10	46606117	1		Planet Carrier
11	46039190	4	8	Planet Gear Pin
12	460391100	12	24	Planet Gear Washer
13	46038191	4	8	Planet Gear (21T)
14	1008680	1	3	O-Ring
15	207564PT	1		Pinion Shaft
16	207555PT	1		Cover
17	60888	2	6	O-Ring
18	207557PT	1		Spacer
19	884083	1	2	Thrust Washer

(#) Quantity
(X) Recommended Spare Parts
(T) Teeth

Models
48EP(E)1000D8

“N”

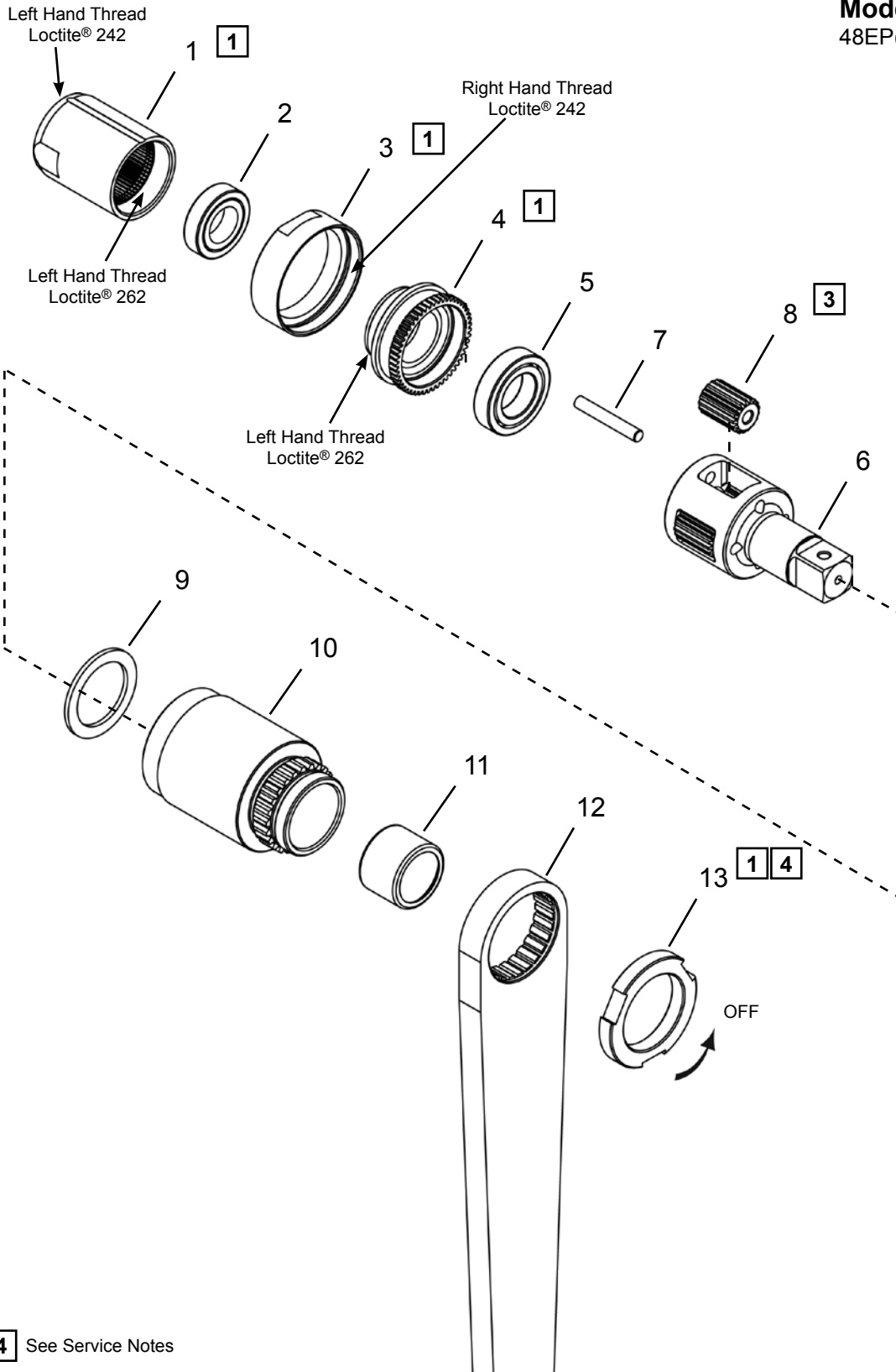

1 3 4 See Service Notes

Cleco®
Gearing - Output

PL12-1006EN
11/26/2012

Illustration "N"

Ref	Number	#	X	EN
				Description
1	46037183	1		Gear Housing
2	92100031	1	2	Ball Bearing
3	46608127	1		Clamp Nut
4	46607114	1		Gear Housing Adapter
5	92100165	1	2	Ball Bearing
6	46606115	1		Output Spindle (1" Square Drive)
7	46608122	4	8	Planet Gear Pin
8	46608121	4	8	Planet Gear (17T)
9	46609119	1	1	Thrust Washer
10	46606116	1		Gear Housing
11	92190034	1	2	Needle Bearing
12	46036202	1		Torque Bar
13	46038134	1		Lock Nut

(#) Quantity

(X) Recommended Spare Parts

(T) Teeth

1 Torque Specifications			
Illustration	Reference	Tightening torque	
		Ft-Lbs (in-lbs)	Nm
E1, E2	1	(10-14)	1,1 - 1,6
	2	(10-14)	1,1 - 1,6
	4	(10-14)	1,1 - 1,6
	5	(50-55)	5,6 - 6,2
	13 (Swivel)	15-18	20-25
G1, G2	1	(4-6)	0,45 - 0,68
	6	(4-6)	0,45 - 0,68
I	1	35-40	47-54
	2	35-40	47-54
	4	65-70	88-102
	6	65-70	88-102
	8	8-10	11 - 13
J	4	65-75	88 - 102
	11	125-135	170 - 183
K	5	65-75	88 - 102
	16	125-135	170 - 183
L	7	125-135	170 - 183
	11	40-50	54 - 68
M	1	65-75	88 - 102
N	1	125-135	170 - 183
	3	65-75	88-102
	4	550-570	745-772
	13	40-50	54 - 68

2 Transducer Identification

Part ID Stamped on this end

5

Transducers are not interchangeable, check part number.

3 Gearing Lubrication

Illustration "H"
540395 - Teflon Grease (2 oz. Tube) *
518156 - Teflon Grease (16 oz. Can)

Illustrations "J-K-M-N"
94380020 - Grease (14 oz. Tube)

Idler Gears

Pinion Gears

Bevel Gears

* 45-1982 Grease Gun for 2 oz. grease tube

4 Spanner Wrench

Illustration "L"

Spanner Wrench

Pin - 3/16"

Off

Illustration "N"

Spanner Wrench

Lug

Off

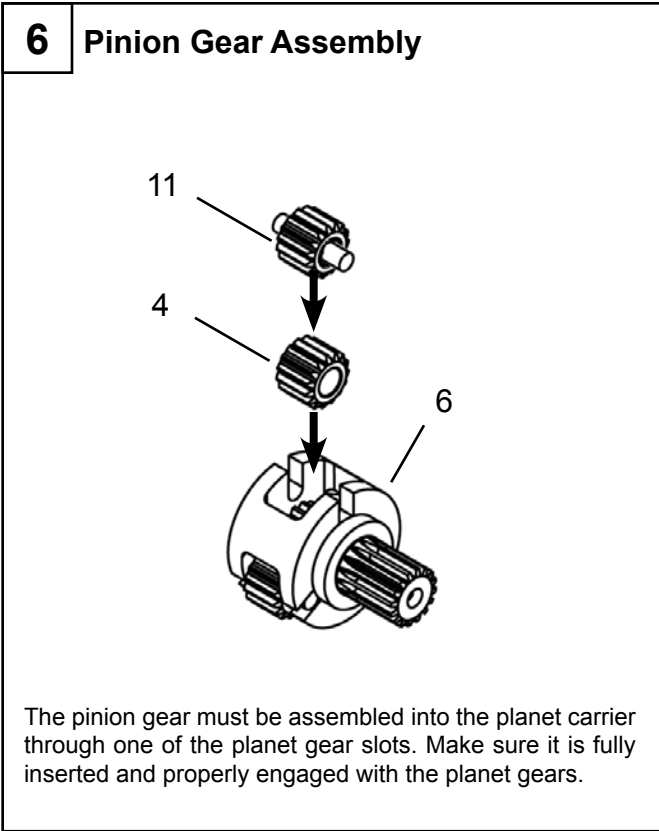
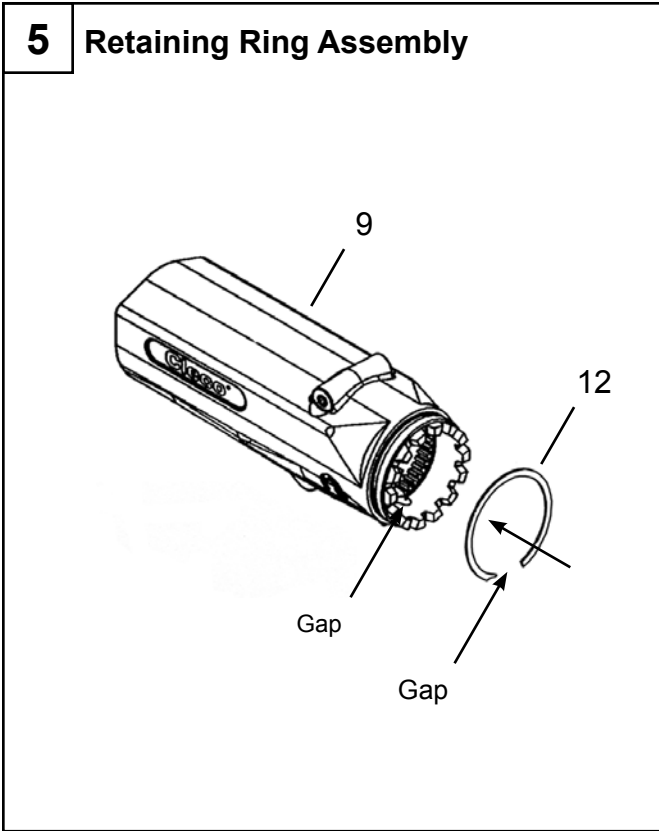

48EP(E) Tool Memory Parameters

Model Number	Max Speed [RPM]	Max Torque [Nm]	Torque Cal [Nm]	Transducer Type	Angle Cal [PPD]	Static Current Factor [Nm/A]
48EP(E)200D6	178	200	282.9741	541846-12	479.1795	10.9048
48EP(E)325D6	107	325	472.9710	541846-12	800.9143	18.2266
48EP(E)500D6	53	500	903.0329	541846-12	1609.6500	34.7997
48EP(E)1000D8	33	1000	1449.6660	541846-12	2584.0198	55.8650

Sales & Service Centers

Note: All locations may not service all products. Please contact the nearest Sales & Service Center for the appropriate facility to handle your service requirements.

Detroit, MI
**Apex Tool Group
Sales & Service Center**
2630 Superior Court
Auburn Hills, MI 48326
Tel: 248-393-5640
Fax: 248-391-6295

Houston, TX
**Apex Tool Group
Sales & Service Center**
6550 West Sam Houston
Parkway North, Suite 200
Houston, TX 77041
Tel: 713-849-2364
Fax: 713-849-2047

Lexington, SC
Apex Tool Group
670 Industrial Drive
Lexington, SC 29072
Tel: 800-845-5629
Tel: 803-951-7544
Fax: 803-358-7681

Los Angeles, CA
**Apex Tool Group
Sales & Service Center**
6881 Stanton Avenue
Unit B
Buena Park, CA 90621
Tel: 562-623-4457
Fax: 562-802-1718

Seattle, WA
**Apex Tool Group
Sales & Service Center**
2865 152nd Avenue N.E.
Redmond, WA 98052
Tel: 425-497-0476
Fax: 425-497-0496

York, PA
**Apex Tool Group
Sales & Service Center**
3990 East Market Street
York, PA 17402
Tel: 717-755-2933
Fax: 717-757-5063

Canada
**Apex Tool Group
Sales & Service Center**
5925 McLaughlin Road
Mississauga, Ont. L5R 1B8
Canada
Tel: 905-501-4785
Fax: 905-501-4786

Germany
**Apex Tool Group
GmbH & Co. OHG**
Industriestraße 1
73463 Westhausen
Germany
Tel: +49 (0) 73 63 81 0
Fax: +49 (0) 73 63 81 222

England
**Apex Tool Group
GmbH & Co. OHG**
C/O Spline Gauges
Piccadilly, Tamworth
Staffordshire B78 2ER
United Kingdom
Tel: +44 1827 8741 28
Fax: +44 1827 8741 28

France
Apex Tool Group S.N.C.
25 rue Maurice Chevalier
B.P. 28
77831 Ozoir-La-Ferrière
Cedex, France
Tel: +33 1 64 43 22 00
Fax: +33 1 64 43 17 17

China
Cooper (China) Co., Ltd.
a company of
Apex Tool Group, LLC
955 Sheng Li Road,
Heqing Pudong, Shanghai
China 201201
Tel: +86-21-28994176
Fax: +86-21-51118446

Mexico
**Cooper Tools
de México S.A. de C.V.**
a company of
Apex Tool Group, LLC
Vialidad El Pueblito #103
Parque Industrial Querétaro
Querétaro, QRO 76220
Mexico
Tel: +52 (442) 211-3800
Fax: +52 (442) 103-0443

Brazil
Cooper Tools Industrial Ltda.
a company of
Apex Tool Group, LLC
Av. Liberdade, 4055
Zona Industrial - Iporanga
18087-170 Sorocaba
SP Brazil
Tel: +55 15 2383929
Fax: +55 15 2383260

Hungary
**Apex Tool Group
Hungaria Kft**
Platánfa u.2
9027 Györ
Hungary
Tel: +36 96 66 1383
Fax: +36 96 66 1135

Apex Tool Group, LLC
1000 Lufkin Road
Apex, NC 27539
Phone: 919-387-0099
Fax: 919-387-2614
www.apextoolgroup.com

Cleco®