

Parts Manual  
PL12EN-48EP  
03/16/2015

# Cleco<sup>®</sup>

**48EP Series**  
Electronically Controlled Pistol Grip Nutrunner



For additional product information visit our website at <http://www.apextoolgroup.com>

**“A”**

<b>48</b>	<b>E</b>	<b>P</b>	<b>X</b>	<b>XXX</b>	<b>XX</b>	<b>X</b>
-----------	----------	----------	----------	------------	-----------	----------

Tool Series

**48**

Motor Style

**E** = Brushless Electric Motor

Tool Type

**P** = Pistol Grip

Feature

- = Matrix Tool Connector (Standard)

**E** = Air LB Connector

Maximum Torque Nm (rounded to nearest Nm)

**12** = 12 Nm (Q, D2)

**25** = 25 Nm (D3)

**36** = 36 Nm (D3)

**48** = 48 Nm (D3)

Attachment

**D2** = 1/4" Square Drive

**D3** = 3/8" Square Drive

**Q** = 1/4" Hex Slip Chuck

Spindle Type

- = Pin Retainer (Standard)

**B** = Ball Retainer

The original language of this manual is English.

### Product Safety Information:

Intended Use:

These DC electric tools are intended for tightening of threaded joints or running down fasteners. Use only for their designated purpose. Do not use in any improper manner that could cause damage to the tool or injure the operator.

For additional product safety information refer to Apex Tool Group, LLC or Apex Tool Group GmbH & Co. OHG document GS-2002, General Safety Instructions Electric Assembly Tools.

### **WARNING**

This DC electric assembly tool must not be modified in any manner unless approved in writing by Apex Tool Group, LLC or Apex Tool Group GmbH & Co. OHG. All safety devices must be properly installed and maintained in good working order. Abuse, misuse, or failure to obey this and any other issued warnings may result in injury or death.

### EC Declaration of Conformity:

We affirm that the product specified herein is to be considered a machine in conjunction with a fastening control from Apex Tool Group. We further declare that this machine is in accordance with the following EC Regulations, 2006/42/EC and 2004/108/EC. Applied harmonized standards are ISO 12100:2010.

The name, job function and address of the person authorized to compile the technical file.

Mr. Vishnu Irigireddy  
Director of Global R&D- Mechanical Engineering  
Apex Tool Group  
670 Industrial Drive  
Lexington, SC 29072



Signature: Vishnu Irigireddy  
Date: April 21, 2014

### Noise and Vibration:

48EP Series: Noise Level  $\leq 68$  dB(A)  
48EPE Series: Noise Level  $\leq 68$  dB(A)  
48EP Series: Vibration  $< 2.5$  m/s<sup>2</sup>  
48EPE Series: Vibration  $< 2.5$  m/s<sup>2</sup>

### Service and Repair:

Tool service and repair should be performed by an authorized Apex Tool Group, LLC or Apex Tool Group GmbH & Co. OHG Center. Refer to the last page of this manual for locations.

### Disposal:



Observe local disposal guidelines for all components of this tool and its packaging.

### Copyright Protection:

Apex Tool Group, LLC or Apex Tool Group GmbH & Co. OHG reserves the right to modify, supplement or improve this document or the product without prior notice. This document may not be reproduced in any way, shape or form, in full or parts thereof, or copied to another natural or machine readable language or to a data carrier, whether electronic, mechanical, optical or otherwise without the express permission of Apex Tool Group, LLC or Apex Tool Group GmbH & Co. OHG

**“B”**

**m-Pro-400 Series**  
Controller



**TME-200 Series**  
Controller



Complete Tool
Order Number
48EP(E)12Q
48EP(E)12D2
48EP(E)25D3
48EP(E)25D3B
48EP(E)36D3
48EP(E)36D3B
48EP(E)48D3
48EP(E)48D3B

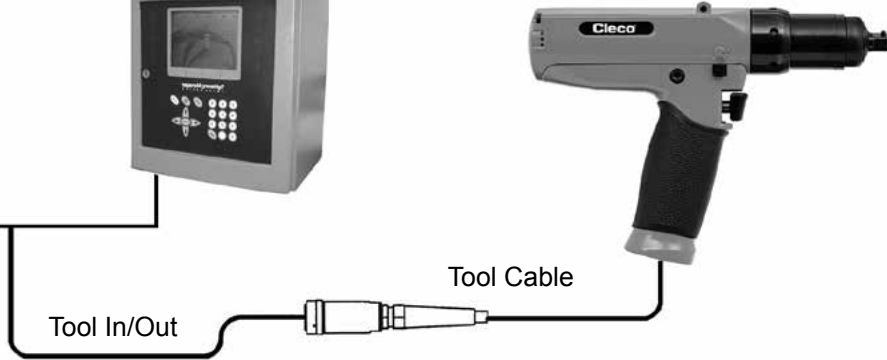

**m-Pro-400GC**  
Global Controller



**m-Pro-400-IT**  
Isolation Transformer  
(48EP Models)



**TME and m-Pro-400 Series Controllers**

48EP	48EPE	EN	
		Description	
115 VAC	Standard	TMEI-114-15-U	
115 VAC	DeviceNet	TMEI-114-15-U-ED	
115 VAC	ProfiBus	TMEI-114-15-U-EP	
TME-200	m-Pro-400	Controller	
PL12( )-1300	*	Programming Notes	
575708	*	Battery	
541683-01	*	Power Cord: 115VAC - USA	
541683-02	*	Power Cord: 230VAC - USA	
541683-03	*	Power Cord: 230VAC - Europe	
542779-XXX	301877-XXX	Extension Cable	
544056-XXX	301904-XXX	Swivel Cable	
544055-XXX	301903-XXX	Swivel Cable - Right Angle	
542778-XXX	301866-XXX	Tool Cable	

\* Note: Contact Apex Tool Group

**TME-200 Series Controller**

Supply Voltage	EN	
	Order Number	
115 VAC	TME-211-15-U	
115 VAC	TME-221-15-U	
230 VAC	TME-211-30-U	
230 VAC	TME-221-30-U	

**“C”**

**Front View**

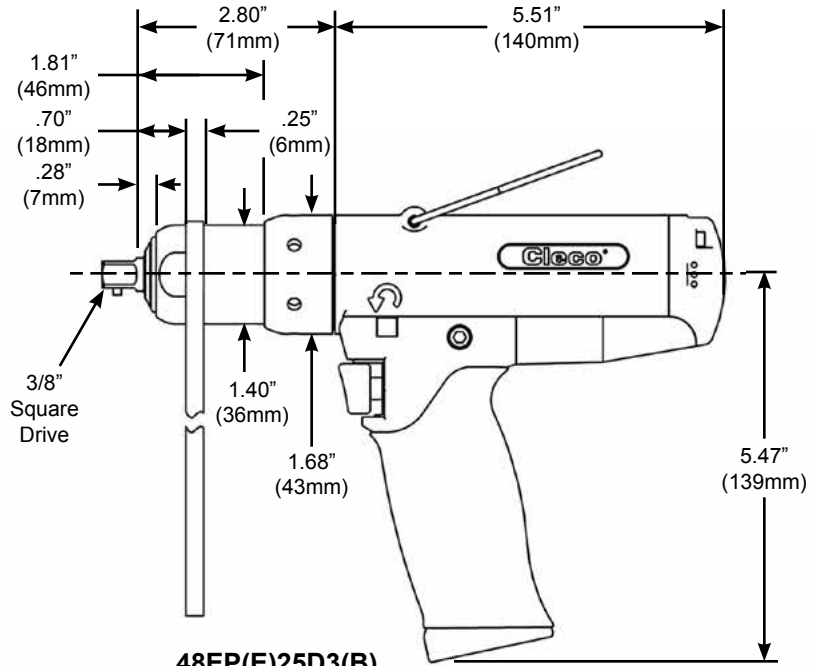
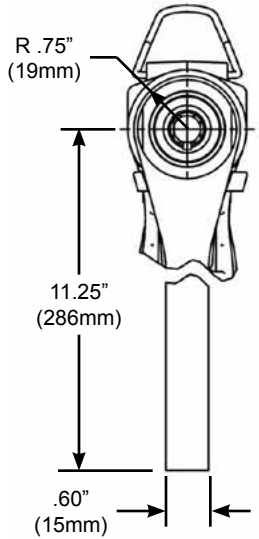

**48EP(E)25D3(B)**  
**48EP(E)36D3(B)**  
(Pin Lock Shown)

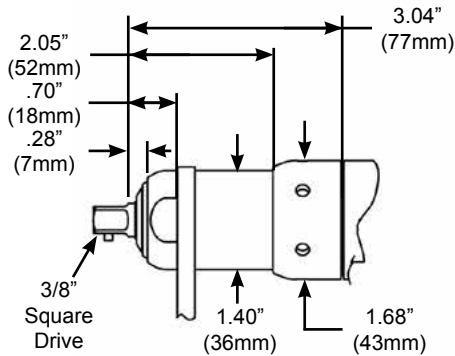

**48EP(E)48D3(B)**  
(Pin Lock Shown)

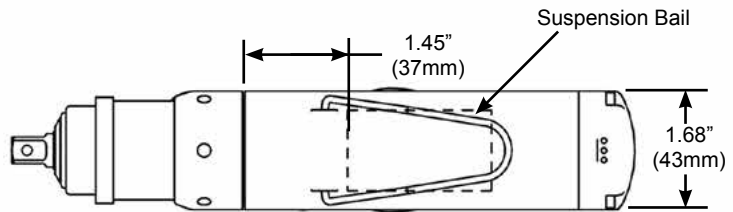

**Top View**

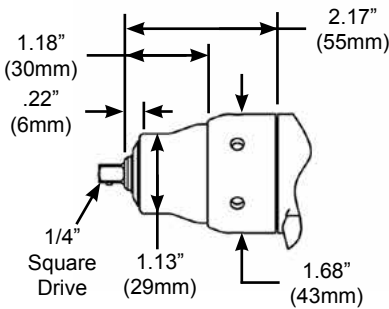

**48EP(E)12D2(B)**  
(Pin Lock Shown)

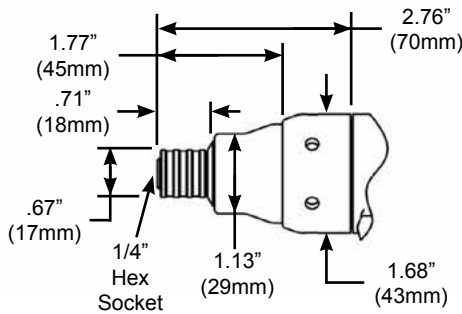

**48EP(E)12Q**

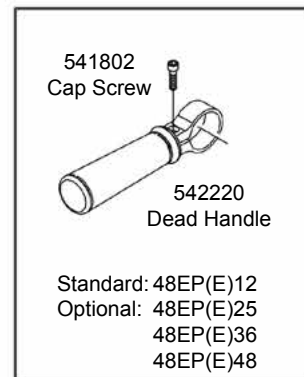

**Cleco®**  
Handle - Matrix Tool Connector

**“D1”**

**Models**  
48EP12  
48EP25  
48EP36  
48EP48

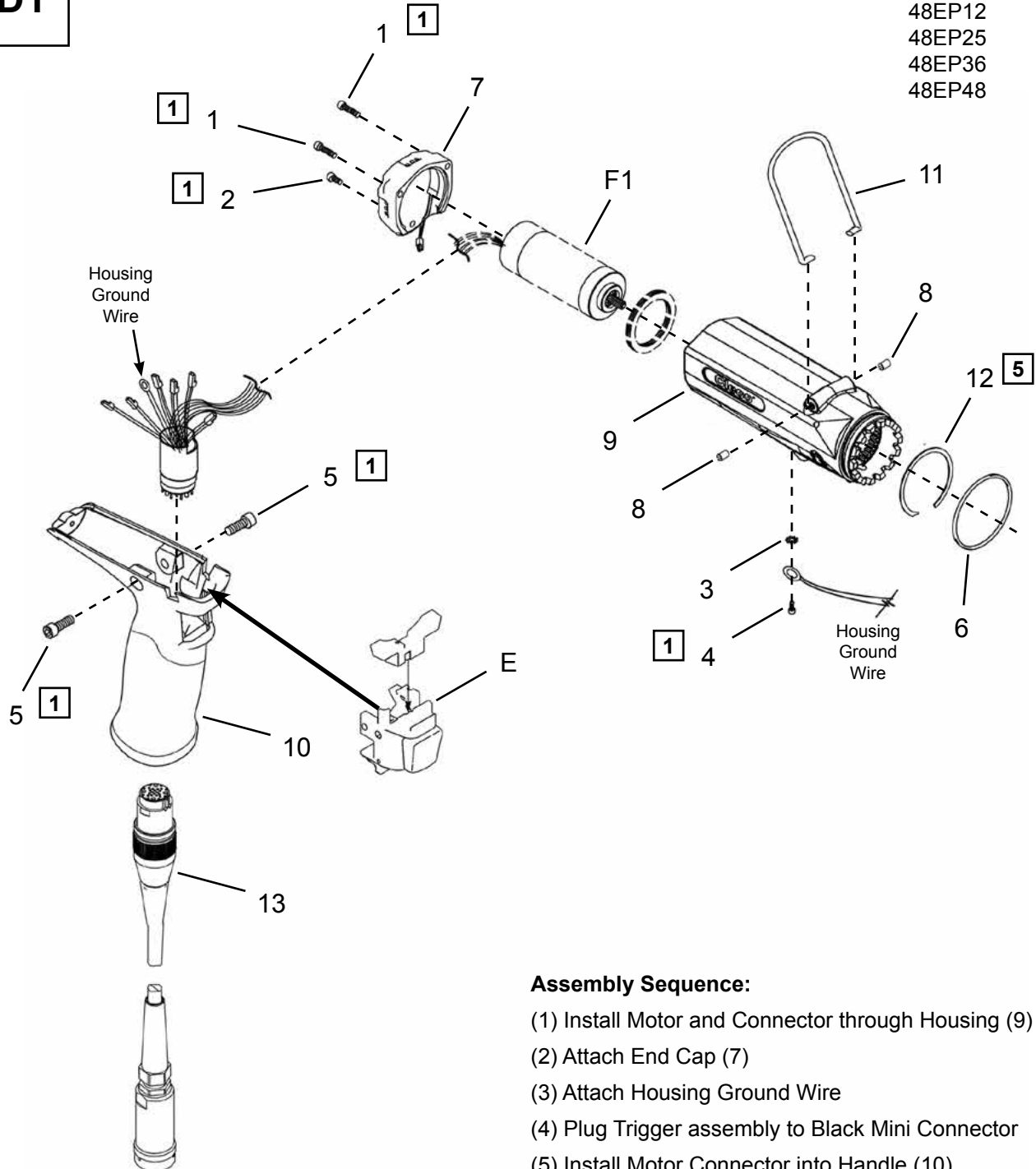

**Assembly Sequence:**

- (1) Install Motor and Connector through Housing (9)
- (2) Attach End Cap (7)
- (3) Attach Housing Ground Wire
- (4) Plug Trigger assembly to Black Mini Connector
- (5) Install Motor Connector into Handle (10)
- (6) Install Trigger assembly into Handle (10)  
(See Illustration “E”)
- (7) Install Reverse Actuator components into Trigger  
(See Illustration “E”)

**1 5** See Service Notes

Handle - Matrix Tool Connector

Illustration "D1"

Ref	Number	#	X	EN	
				Description	
1	B121A	2	4	Cap Screw	
2	B124R	1	3	Cap Screw	
3	W115	1	3	Lock Washer	
4	541927	1	3	Screw	
5	B122S	2	4	Cap Screw	
6	22598	1	3	O-Ring	
7	542820	1		Rear Cap	
8	931791	2	4	Spring Pin	
9	542679	1		Top Handle (includes Ref. 8)	
10	207338	1		Bottom Handle	
11	931962	1	1	Suspension Bail	
12	505306	1	1	Retaining Ring	
<b>Tool Cable (Optional Length)</b>					
13	542778-1M	1		1 meter cable	
	542778-2M			2 meter cable	
	542778-3M			3 meter cable	
	542778-6M			6 meter cable	
	542778-8M			8 meter cable	
	542778-10M			10 meter cable	
	542778-15M			15 meter cable	
	542778-50M			50 meter cable	
<b>Inline Swivel Cable (Optional Length)</b>					
13	544056-1M	1		1 meter cable	
	544056-2M			2 meter cable	
	544056-3M			3 meter cable	
	544056-6M			6 meter cable	
	544056-8M			8 meter cable	
	544056-10M			10 meter cable	
	544056-15M			15 meter cable	
<b>Angle Swivel Cable (Optional Length)</b>					
13	544055-1M	1		1 meter cable	
	544055-2M			2 meter cable	
	544055-3M			3 meter cable	
	544055-6M			6 meter cable	
	544055-8M			8 meter cable	
	544055-10M			10 meter cable	
	544055-15M			15 meter cable	
<b>Tool Cable Extension (Optional Length)</b>					
13	542779-1M	1		1 meter cable	
	542779-2M			2 meter cable	
	542779-3M			3 meter cable	
	542779-6M			6 meter cable	
	542779-10M			10 meter cable	
	542779-15M			15 meter cable	
	542779-50M			50 meter cable	

(#) Quantity

(X) Recommended Spare Parts (quantity shown based on 1-5 tools in operation)

**Cleco®**  
Handle - Air LB Tool Connector

**“D2”**

**Models**  
48EPE12  
48EPE25  
48EPE36  
48EPE48

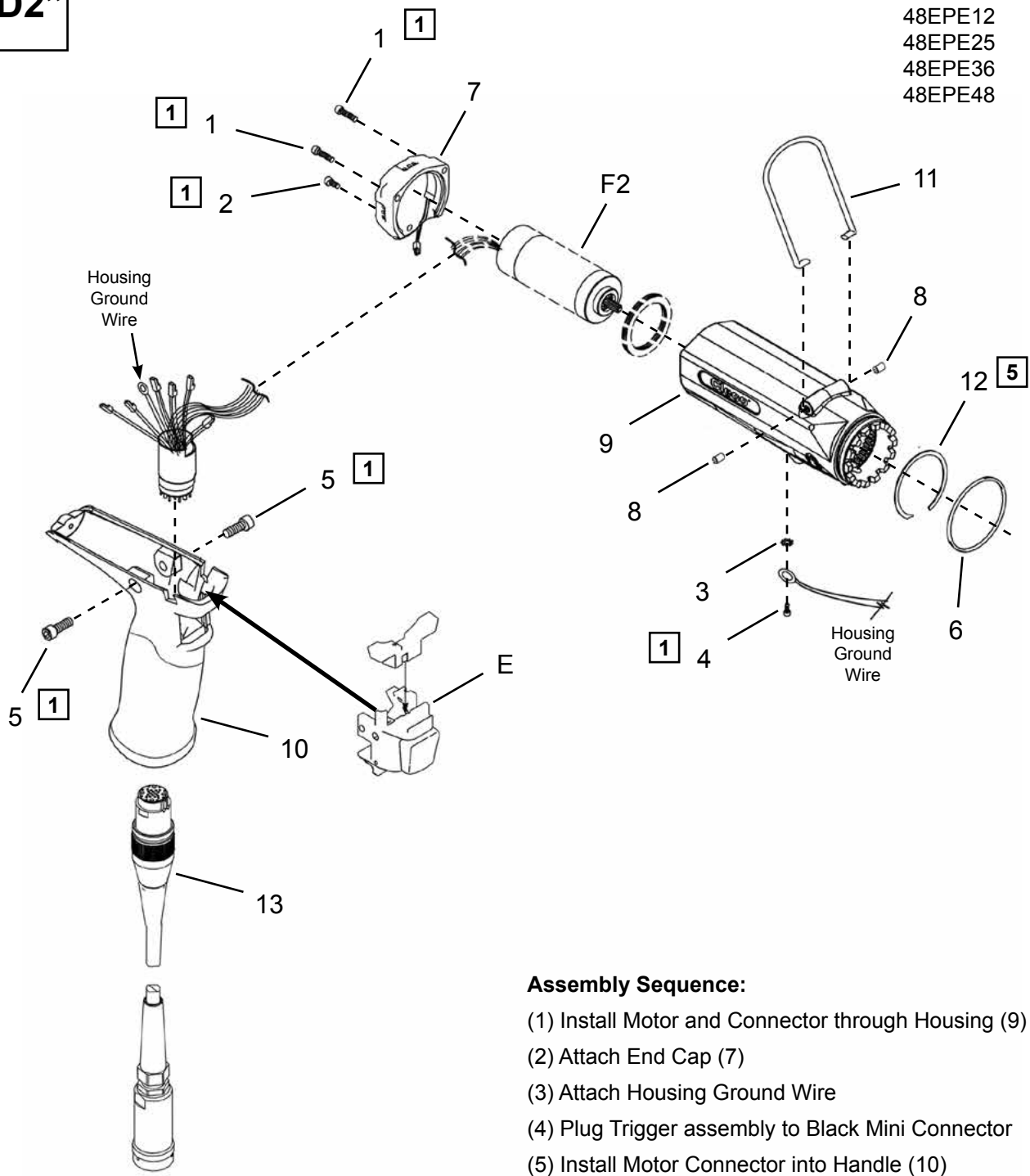

- Assembly Sequence:**
- (1) Install Motor and Connector through Housing (9)
  - (2) Attach End Cap (7)
  - (3) Attach Housing Ground Wire
  - (4) Plug Trigger assembly to Black Mini Connector
  - (5) Install Motor Connector into Handle (10)
  - (6) Install Trigger assembly into Handle (10)  
(See Illustration “E”)
  - (7) Install Reverse Actuator components into Trigger  
(See Illustration “E”)

**1 5** See Service Notes



**Handle - Air LB Tool Connector**

**Illustration "D2"**

Ref	Number	#	X	EN	
				Description	
1	B121A	2	4	Cap Screw	
2	B124R	1	3	Cap Screw	
3	W115	1	3	Lock Washer	
4	541927	1	3	Screw	
5	B122S	2	4	Cap Screw	
6	22598	1	3	O-Ring	
7	542820	1		Rear Cap	
8	931791	2	4	Spring Pin	
9	542679	1		Top Handle (includes Ref. 8)	
10	207338E	1		Bottom Handle	
11	931962	1	1	Suspension Bail	
12	505306	1	1	Retaining Ring	
<b>Tool Cable (Optional Length)</b>					
13	301866-2M	1		2 meter cable	
	301866-3M			3 meter cable	
	301866-4M			4 meter cable	
	301866-6M			6 meter cable	
	301866-8M			8 meter cable	
	301866-10M			10 meter cable	
	301866-15M			15 meter cable	
<b>Inline Swivel Cable (Optional Length)</b>					
13	301904-2M	1		2 meter cable	
	301904-3M			4 meter cable	
	301904-8M			8 meter cable	
	301904-15M			15 meter cable	
<b>Angle Swivel Cable (Optional Length)</b>					
13	301903-2M	1		2 meter cable	
	301903-3M			4 meter cable	
	301903-8M			8 meter cable	
	301903-15M			15 meter cable	
<b>Tool Cable Extension (Optional Length)</b>					
13	301877-4M	1		4 meter cable	
	301877-8M			8 meter cable	
	301877-10M			10 meter cable	
	301877-20M			20 meter cable	
	301877-30M			30 meter cable	
	301877-40M			40 meter cable	
	301877-50M			50 meter cable	

(#) Quantity

(X) Recommended Spare Parts (quantity shown based on 1-5 tools in operation)

# Cleco® Trigger Assembly

“E”

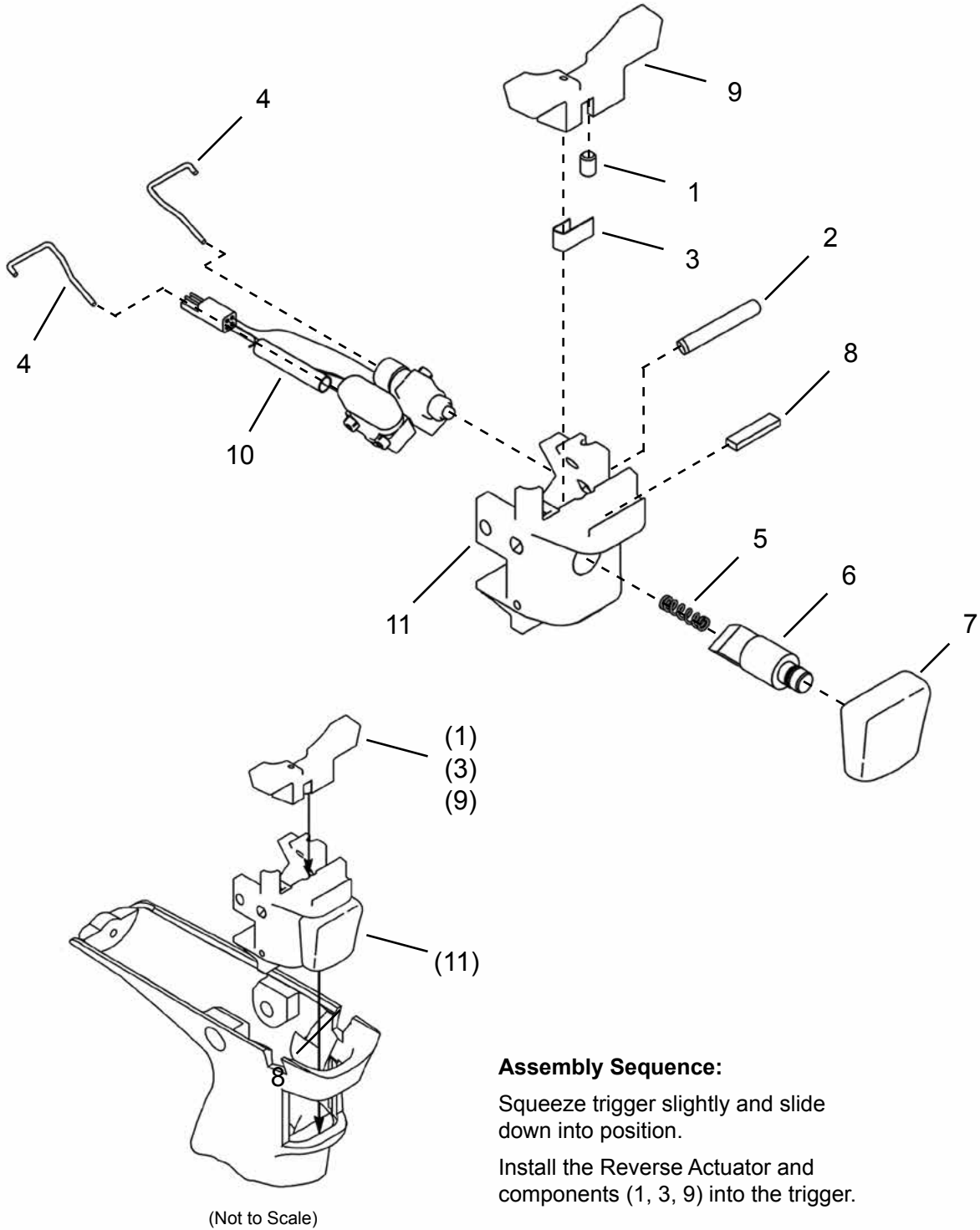

**Cleco®**  
Trigger Assembly

**PL12EN-48EP**  
03/16/2015

**Illustration "E"**

Ref	Number	#	X	EN
				Description
1	1007441	1	3	Detent Pin
2	843280	1	2	Pin
3	207541PT	1		Leaf Spring
4	935077	2	3	Spring Pin
5	913365	1	3	Spring
6	207315	1		Trigger Shaft
7	1110038	1		Trigger
8	542088	1	3	Foam Pad
9	207314	1		Reverse Actuator
10	301729	1	2	Start / Reverse Switch
11	207313	1		Switch Housing

(#) Quantity

(X) Recommended Spare Parts (quantity shown based on 1-5 tools in operation)

# Cleco®

## Motor - Matrix Tool Connector

**“F1”**

**Models**  
48EP12  
48EP25  
48EP36  
48EP48

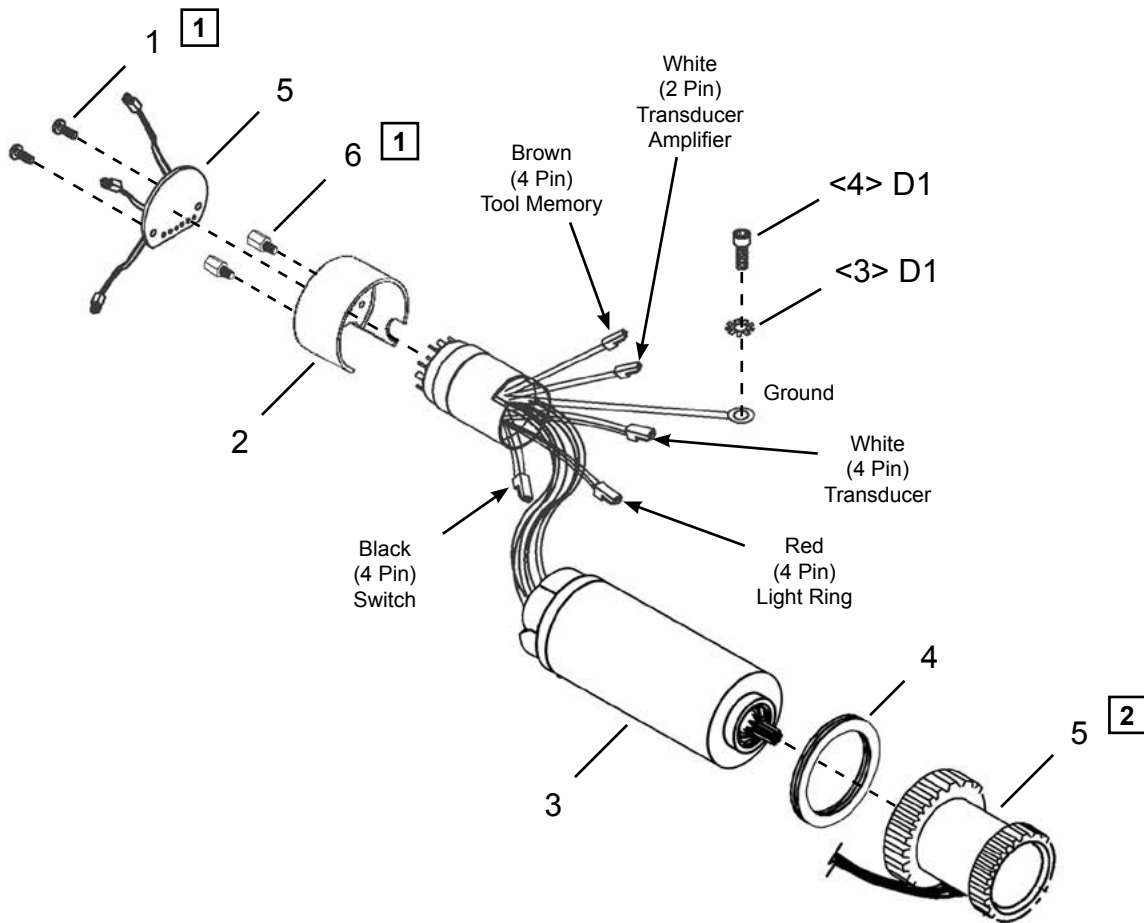

**1** **2** See Service Notes

**Motor - Matrix Tool Connector**

**Illustration "F1"**

Ref	Number	#	X	EN
				Description
1	17-111	2	4	Pan Head Screw - #4-40 x .19
2	542588	1		Motor Spacer
3	301761	1		Motor Assembly
4	542098	1	2	Wave Spring
5	Table "F1"	1		Transducer Assembly
6	542244	2	2	Stand Off

(#) Quantity

(X) Recommended Spare Parts (quantity shown based on 1-5 tools in operation)

**Table "F1"**

Ref.	Description	#	48EP12Q 48EP12D2	#	48EP25D3	#	48EP36D3	#	48EP48D3
5	Transducer (unprogrammed)	1	542846-12	1	542846-31	1	542846-36	1	542846-48
	Transducer (programmed)	1	542846-12P	1	542846-31P	1	542846-36P	1	542846-48P
	Transducer Capacity		12 Nm		31 Nm		36 Nm		48 Nm

# Cleco®

## Motor - Air LB Tool Connector

“F2”

### Models

48EPE12  
48EPE25  
48EPE36  
48EPE48

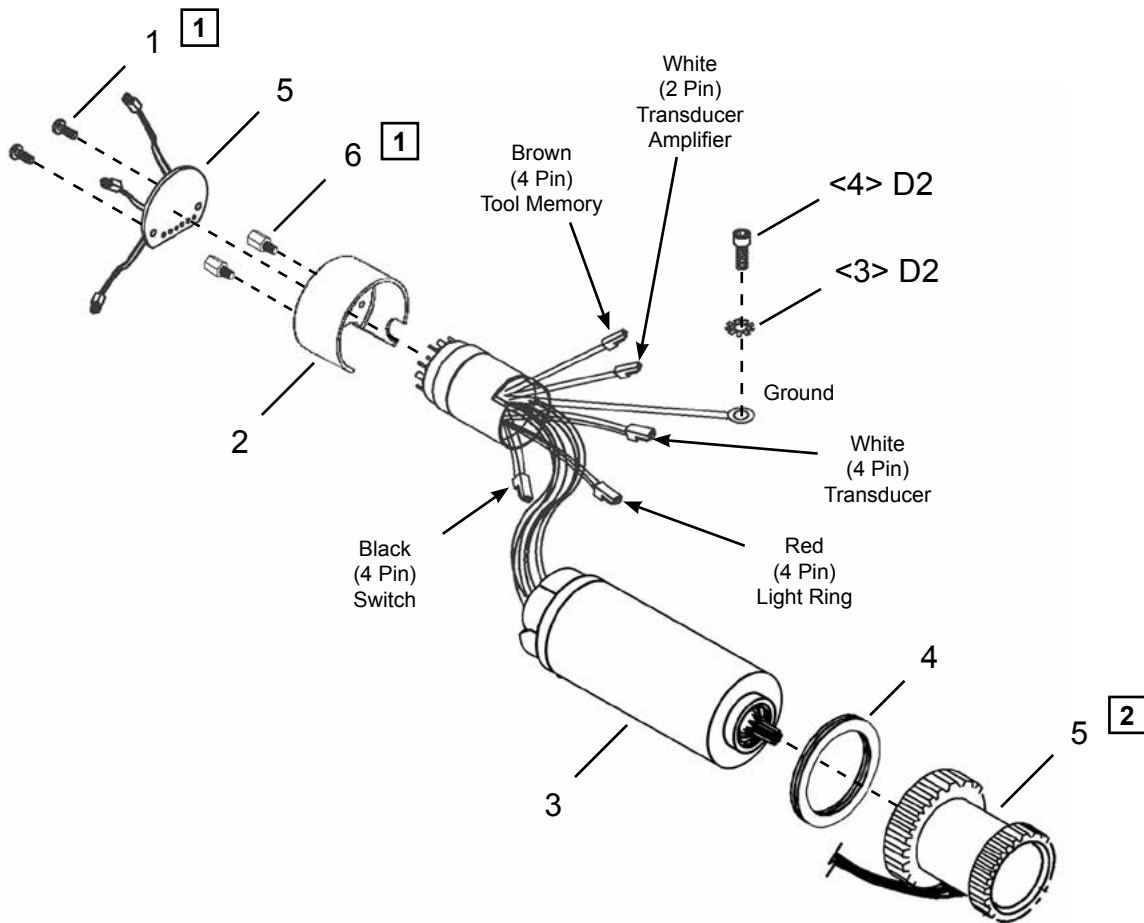

1 2 See Service Notes

**Cleco®**  
Motor - Air LB Tool Connector

**PL12EN-48EP**  
03/16/2015

**Illustration "F2"**

Ref	Number	#	X	EN
				Description
1	17-111	2	4	Pan Head Screw - #4-40 x .19
2	542588	1		Motor Spacer
3	301761E	1		Motor Assembly
4	542098	1	2	Wave Spring
5	Table "F2"	1		Transducer Assembly
6	542244	2	2	Stand Off

(#) Quantity

(X) Recommended Spare Parts (quantity shown based on 1-5 tools in operation)

**Table "F2"**

Ref.	Description	#	48EPE12Q 48EPE12D2	#	48EPE25D3	#	48EPE36D3	#	48EPE48D3
5	Transducer (unprogrammed)	1	542846-12	1	542846-31	1	542846-36	1	542846-48
	Transducer (programmed)	1	542846-12P	1	542846-31P	1	542846-36P	1	542846-48P
	Transducer Capacity		12 Nm		31 Nm		36 Nm		48 Nm

**“G”**

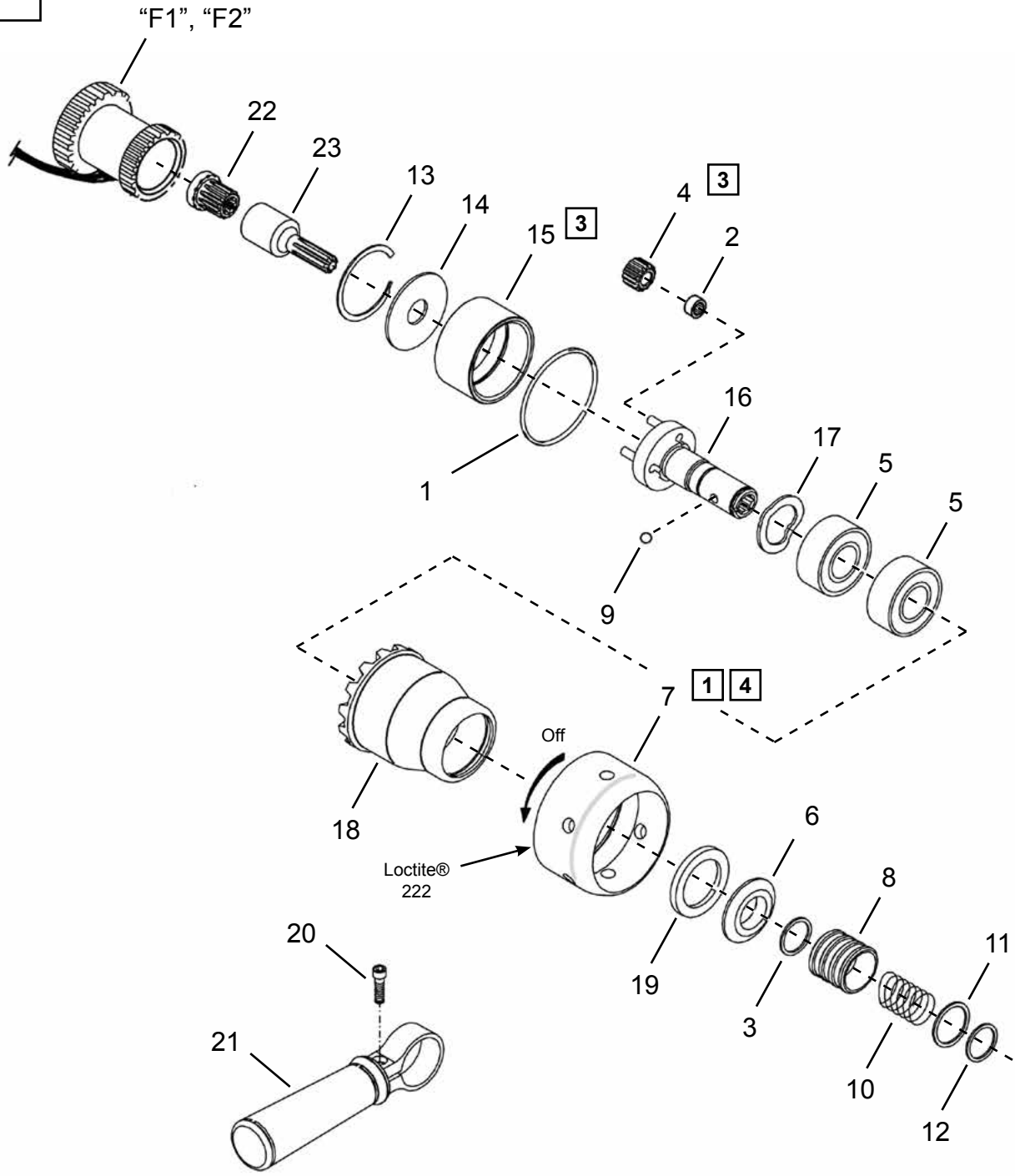

**Dead Handle Assembly**  
(not to scale)

**1 3 4** See Service Notes



**Cleco®**  
Single Stage Gearing

**PL12EN-48EP**  
03/16/2015

**Illustration "G"**

Ref	Number	#	X	EN
				Description
1	1011732	1	4	O-Ring
2	203749	3	6	Needle Bearing
3	833688	1	2	Retaining Ring
4	541893	3	6	Planet Gear (21T)
5	542089	2	4	Ball Bearing
6	541914	1		Spindle Washer
7	541904	1		Front Nut
8	536592	1		Sleeve
9	844265	1	3	Steel Ball (1/8")
10	540842	1	2	Spring
11	540800	1	2	Washer
12	503009	1	2	Retaining Ring
13	800116	1	2	Retaining Ring
14	541887	1		Retention Washer
15	542090	1		Ring Gear (52T)
16	542092	1		Output Spindle
17	1019356	1		Wave Washer
18	542091	1		Gear Case
19	542076	1		Retaining Ring
20	541802	1		Screw
21	542220	1		Dead Handle (Includes Ref. 20)
22	541044	1	2	Pinion Adapter
23	541898	1	2	Extension Pinion

(#) Quantity

(X) Recommended Spare Parts (quantity shown based on 1-5 tools in operation)

(T) Teeth

**Cleco®**  
Single Stage Gearing

**"H"**

**Models**  
48EP(E)12D2(B)

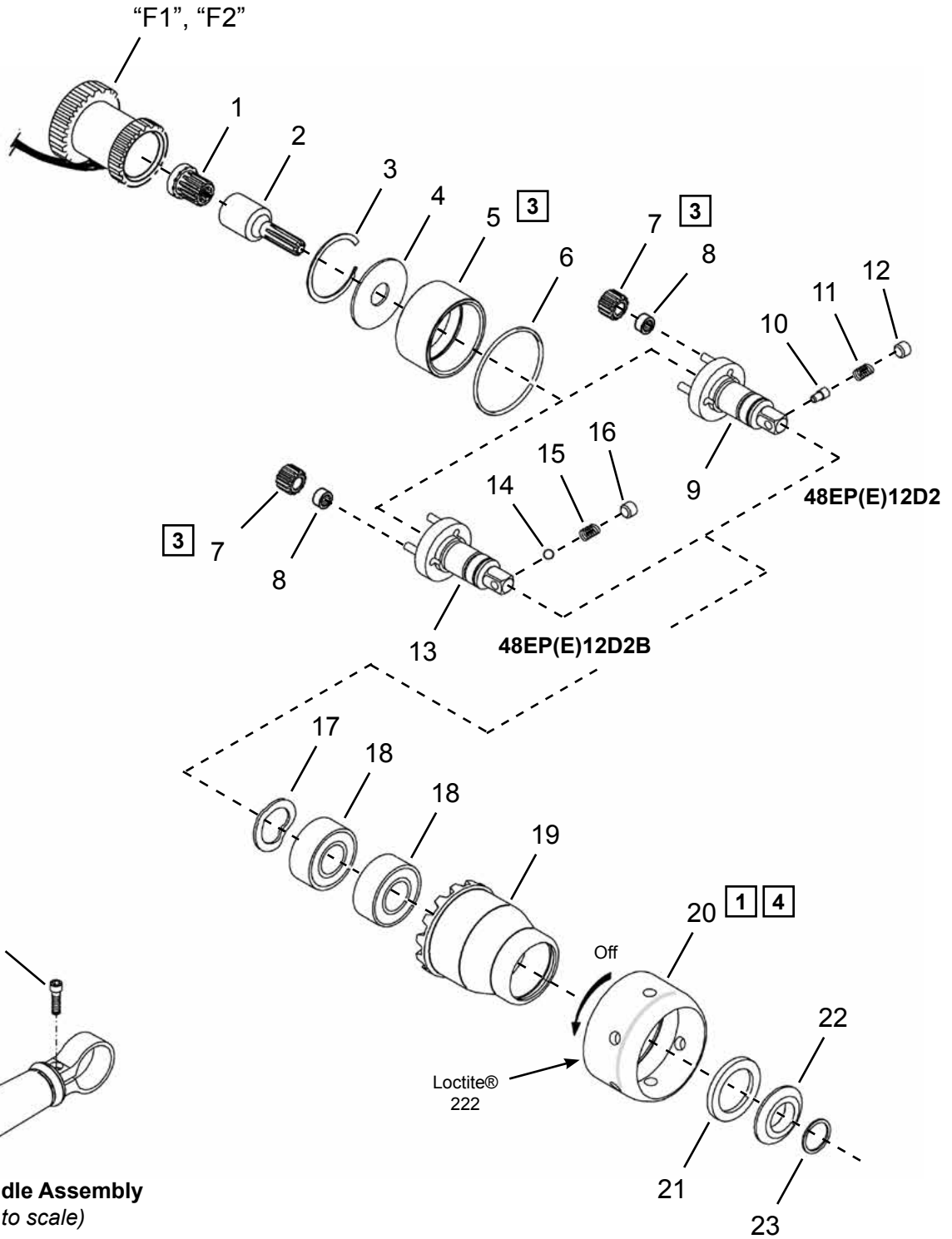

**1 3 4** See Service Notes

**Cleco®**  
Single Stage Gearing

**PL12EN-48EP**  
03/16/2015

**Illustration "H"**

Ref	Number	#	X	EN
				Description
1	541044	1	2	Pinion Adapter
2	541898	1	2	Extension Pinion
3	800116	1	2	Retaining Ring
4	541887	1		Retention Washer
5	542090	1		Ring Gear (52T)
6	1011732	1	4	O-Ring
7	541893	3	6	Planet Gear (21T)
8	203749	3	6	Needle Bearing
9	542093	1		Output Spindle - Pin (includes Ref. 10-12)
10	23569	1	3	Button
11	27722PT	1	3	Spring
12	26989PT	1	3	Plug
13	543423	1		Output Spindle - Ball (includes Ref. 14-16)
14	94010006	1	3	Steel Ball
15	WS-252	1	3	Spring
16	LB-252	1	3	Bushing
17	1019356	1		Wave Washer
18	542089	2	4	Ball Bearing
19	542091	1		Gear Case
20	541904	1		Front Nut
21	542076	1		Retaining Ring
22	541919	1		Spindle Washer
23	800216	1	2	Retaining Ring
24	542220	1		Dead Handle (Includes Ref. 21)
25	541802	1		Screw

(#) Quantity

(X) Recommended Spare Parts (quantity shown based on 1-5 tools in operation)

(T) Teeth

**Cleco®**  
Double Stage Gearing

“1”

**Models**  
48EP(E)25D3(B)  
48EP(E)36D3(B)

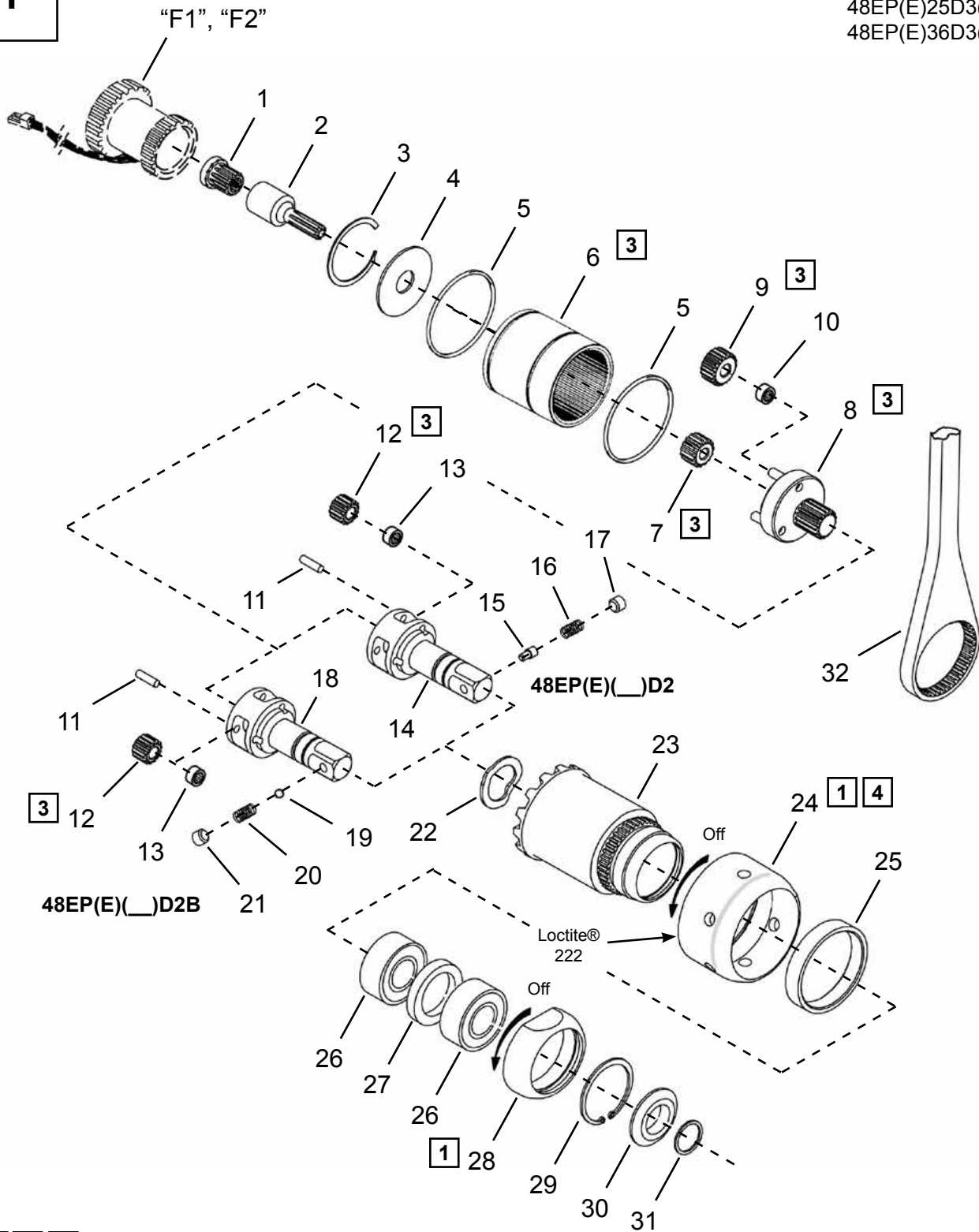

**1 3 4** See Service Notes

**Cleco®**  
Double Stage Gearing

**PL12EN-48EP**  
03/16/2015

**Illustration "I"**

Ref	Number	#	X	EN	
				Description	
1	541044	1	2	Pinion Adapter	
2	541898	1	2	Extension Pinion	
3	800116	1	2	Retaining Ring	
4	541887	1		Washer	
5	542724	2	4	O-Ring	
6	542722	1		Ring Gear	
7	541899	1	2	Slip-On Gear (17T)	
8	Table "I"	1		Idler Plate	
9	541894	3	6	Planet Gear (17T)	
10	203749	3	6	Needle Bearing	
11	541888	3	6	Planet Pin	
12	Table "I"	3	6	Planet Gear	
13	203749	3	6	Needle Bearing	
14	Table "I"	1		Output Spindle - Pin (includes Ref. 15-17)	
15	24499	1	3	Button	
16	9D6481	1	3	Spring	
17	26989PT	1	3	Plug	
18	Table "I"	1		Output Spindle - Ball (includes Ref. 19-21)	
19	1091PT	1	3	Steel Ball	
20	WS-371	1	3	Spring	
21	LB-370	1	3	Plug	
22	1019356	1	2	Wave Washer	
23	542723	1		Gear Case	
24	541904	1		Front Nut	
25	542134	1		Spline Guard	
26	542089	2	4	Ball Bearing	
27	541775	1		Bearing Spacer	
28	542097	1		Retaining Nut	
29	542076	1	3	Retaining Ring	
30	541919	1		Spindle Washer	
31	800216	1	3	Retaining Ring	
32	542127	1		Reaction Bar	

(#) Quantity

(X) Recommended Spare Parts (quantity shown based on 1-5 tools in operation)

(T) Teeth

**Table "I"**

Ref.	Description	#	48EP(E)25D3	#	48EP(E)36D3
8	Idler Plate	1	542230	1	542233
12	Planet Gear	3	541894 (17T)	3	541897 (21T)
14	Output Spindle - Pin	1	541916	1	541917
18	Output Spindle - Ball	1	543424	1	543425

(T) Teeth

**Cleco®**  
Double Stage Gearing

**Models**  
48EP(E)48D3(B)

**“J”**

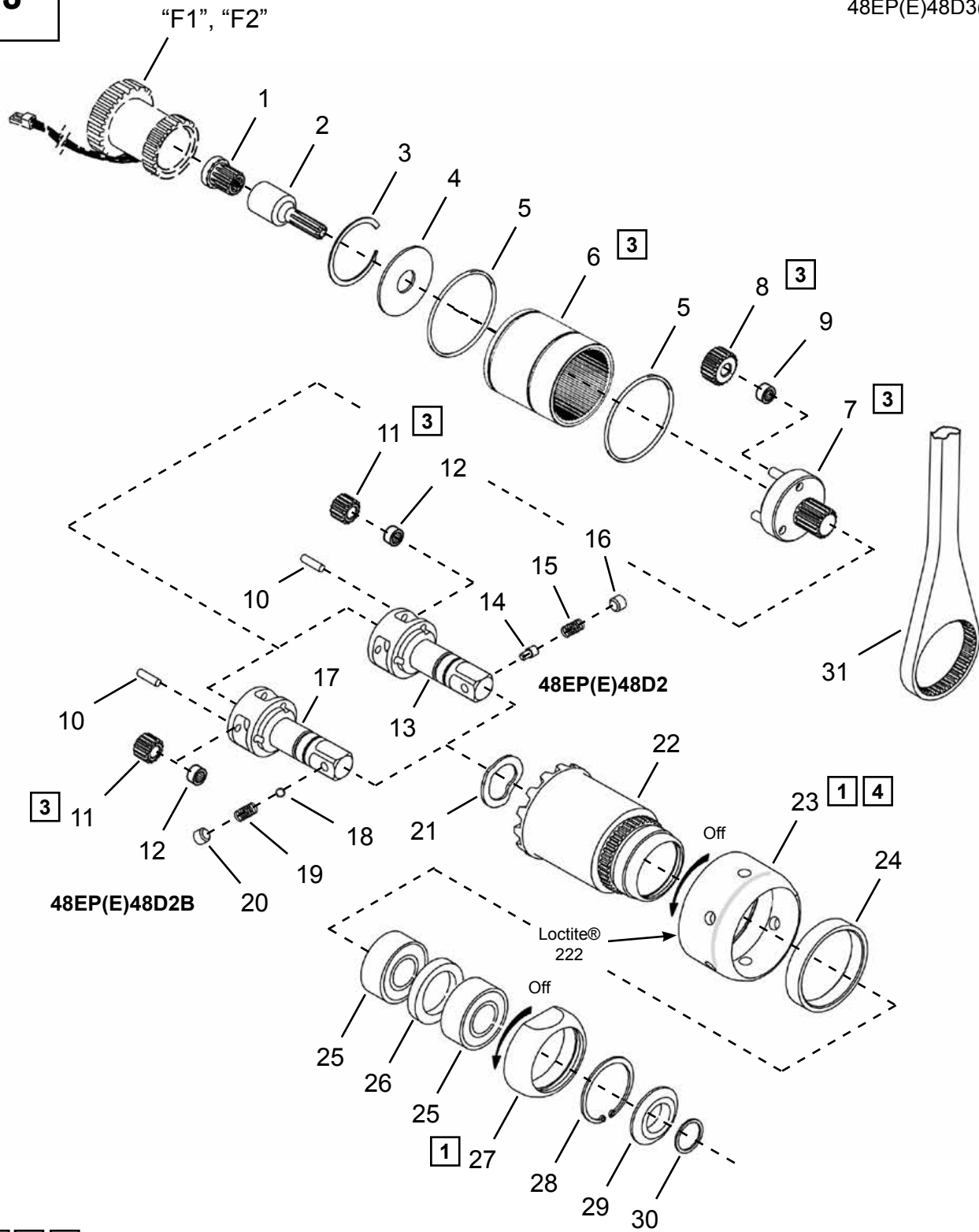

**1 3 4** See Service Notes

**Cleco®**  
Double Stage Gearing

**PL12EN-48EP**  
03/16/2015

**Illustration "J"**

Ref	Number	#	X	EN
				Description
1	541044	1	2	Pinion Adapter
2	541898	1	2	Extension Pinion
3	800116	1	2	Retaining Ring
4	541887	1		Washer
5	542724	2	4	O-Ring
6	542668	1		Ring Gear
7	542671	1		Idler Plate
8	541893	3	6	Planet Gear (21T
9	203749	3	6	Needle Bearing
10	542666	3	6	Planet Pin
11	542669	3	6	Planet Gear (17T)
12	203784PT	3	6	Needle Bearing
13	542670	1		Output Spindle - Pin (includes Ref. 14-16)
14	24499	1	3	Button
15	9D6481	1	3	Spring
16	26989PT	1	3	Plug
17	543426	1		Output Spindle - Ball (includes Ref. 18-20)
18	1091PT	1	3	Steel Ball
19	WS-371	1	3	Spring
20	LB-370	1	3	Plug
21	1019356	1	2	Wave Washer
22	542673	1		Gear Case
23	541904	1		Front Nut
24	542134	1		Spline Guard
25	542089	2	4	Ball Bearing
26	542672	1		Bearing Spacer
27	542097	1		Retaining Nut
28	542076	1	3	Retaining Ring
29	541919	1		Spindle Washer
30	800216	1	3	Retaining Ring
31	542127	1		Reaction Bar

(#) Quantity

(X) Recommended Spare Parts (quantity shown based on 1-5 tools in operation)

(T) Teeth

### 1 Tightening Torque

Illustration	Reference	Tightening torque	
		Ft-Lbs (in-lbs)	Nm
D1, D2	1	(10-14)	1,1-1,6
	2	(10-14)	1,1-1,6
	4	(10-14)	1,1-1,6
	5	(50-55)	5,6-6,2
	13 (Swivel)	15-18	20-25
E1, E2	1	(4-6)	0,45-0,68
	6	(4-6)	0,45-0,68
G	7	35-40	47-54
H	12	35-40	47-54
I	28	30-35	41-47
	24	35-40	47-54
J	27	30-35	41-47
	23	35-40	47-54

### 3 Gear Train Lubrication

541444 - 2 oz. (56 g)  
541445 - 1 pound (0.45 kg)

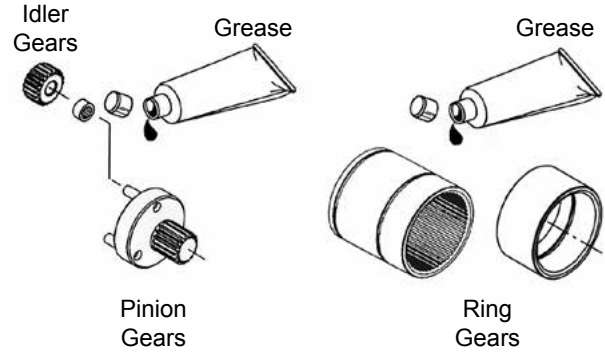

### 2 Transducer Identification

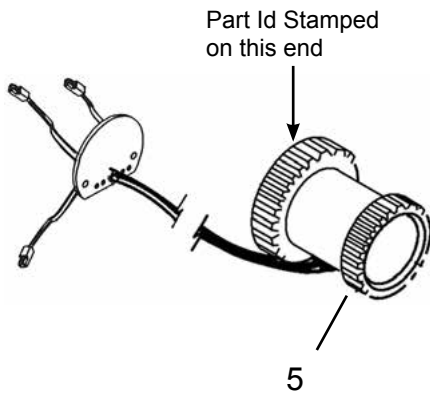

Transducers are not interchangeable, check part number.

### 4 Spanner Wrench

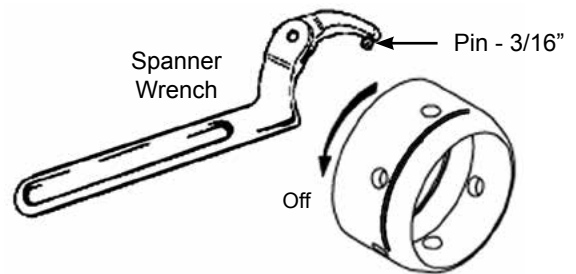



Service Notes & Tool Memory Parameters

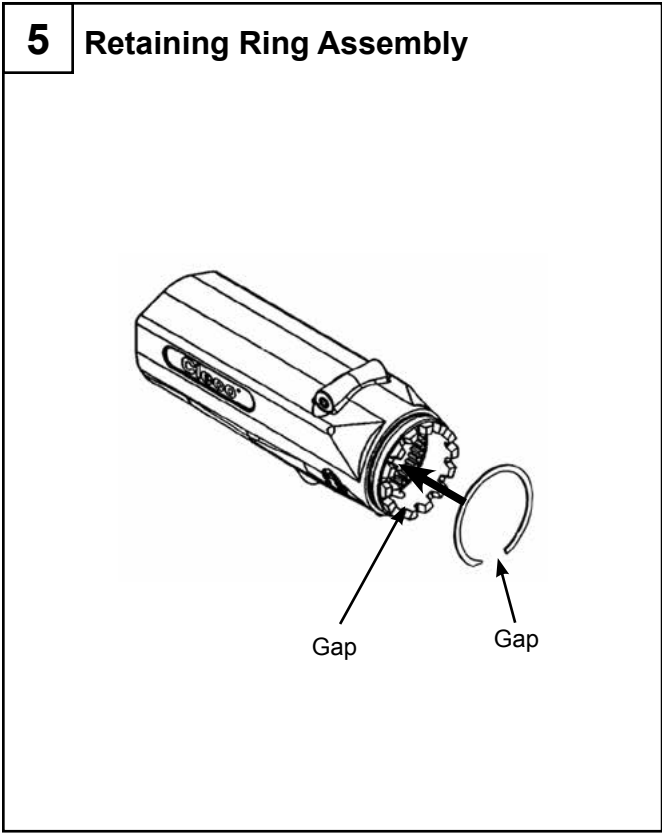

**48EP(E) Tool Memory Parameters**

Model Number	Max Speed [RPM]	Max Torque [Nm]	Torque Cal [Nm]	Transducer Type	Angle Cal [PPD]	Static Current Factor [Nm/A]
48EP(E)12Q	4000	12	13.9592	542846-12	21.3330	0.5379
48EP(E)12D2	4000	12	13.9592	542846-12	21.3330	0.5379
48EP(E)25D3	1820	25	33.2354	542846-31	46.8588	1.1225
48EP(E)36D3	1290	36	37.8018	542846-36	66.1209	1.5840
48EP(E)48D3	985	48	49.8132	542846-48	86.5869	2.0742





## Sales & Service Centers

**Note:** All locations may not service all products. Please contact the nearest Sales & Service Center for the appropriate facility to handle your service requirements.

### Brazil

**Apex Tool Group  
Ind. Com. Ferram. Ltda**  
Av. Liberdade, 4055  
Zona Industrial Iporanga  
Sorocaba, São Paulo  
CEP# 18087-170  
Brazil  
Tel: +55 15 3238 3820  
Fax: +55 15 3238 3938

### Canada

**Apex Tool Canada, Ltd  
Sales & Service Center**  
7631 Bath Road  
Mississauga, Ont. L4T 3T1  
Canada  
Tel: (866) 691-6212  
Tel: (905) 673-4400

### China

**Apex Power Tool Trading (Shanghai)  
Co., Ltd**  
Building A8, No. 38  
Dongsheng Road  
Pudong, Shanghai  
China 201201  
Tel: +86-21-60880320  
Fax: +86-21-60880298  
www.apxpowertools.com.cn

### England

**Apex Tool Group  
GmbH & Co. OHG**  
C/O Spline Gauges  
Piccadilly, Tamworth  
Staffordshire B78 2ER  
United Kingdom  
Tel: +44 1827 872 771  
Fax: +44 1827 8741 28

### France

**Apex Tool Group SAS**  
25 rue Maurice Chevalier  
B.P. 28  
77831 Ozoir-La-Ferrière  
Cedex, France  
Tel: +33 1 64 43 22 00  
Fax: +33 1 64 43 17 17

### Germany

**Apex Tool Group  
GmbH & Co. OHG**  
Industriestraße 1  
73463 Westhausen  
Germany  
Tel: +49 (0) 73 63 81 0  
Fax: +49 (0) 73 63 81 222  
www.apxpowertools.eu

### Hungary

**Apex Tool Group  
Hungaria Kft**  
Platánfa u.2  
9027 Győr  
Hungary  
Tel: +36 96 66 1383  
Fax: +36 96 66 1135

### India

**Apex Power Tools India  
Private Limited**  
Gala No. 1, Plot No. 5  
S. No. 234, 235 & 245  
Indialand Global  
Industrial Park  
Taluka-Mulsi, Phase I  
Hinjawadi, Pune 411057  
Maharashtra, India  
Tel: +91-20-66761111

### Mexico

**Apex Tool Group  
Manufacturing México  
S. de RL de CV**  
Vialidad El Pueblito #103  
Parque Industrial Querétaro  
Querétaro, QRO  
CP# 76220  
Mexico  
Tel: +52 (442) 211-3800  
Fax: +52 (800) 685-5560

### USA - Detroit, Michigan

**Apex Tool Group**  
2630 Superior Court  
Auburn Hills, MI 48326  
Tel: (248) 393-5640  
Fax: (248) 391-6295

### USA - Lexington, South Carolina

**Apex Tool Group**  
670 Industrial Drive  
Lexington, SC 29072  
Tel: (800) 845-5629  
Tel: (803) 951-7544  
Fax: (803) 358-7681

### USA - York, Pennsylvania

**Apex Tool Group**  
3990 East Market Street  
York, PA 17402  
Tel: (717) 755-2933  
Fax: (717) 757-5063

Apex Tool Group, LLC  
1000 Lufkin Road  
Apex, NC 27539  
Phone: 919-387-0099  
Fax: 919-387-2614  
www.apextoolgroup.com

# Cleco®